

TC-35

Gnarly preamp from the
Gorilla TC-35



Before you dig in, ensure you download and read the **General Build Guide**.

It contains all the information you need for a successful outcome.

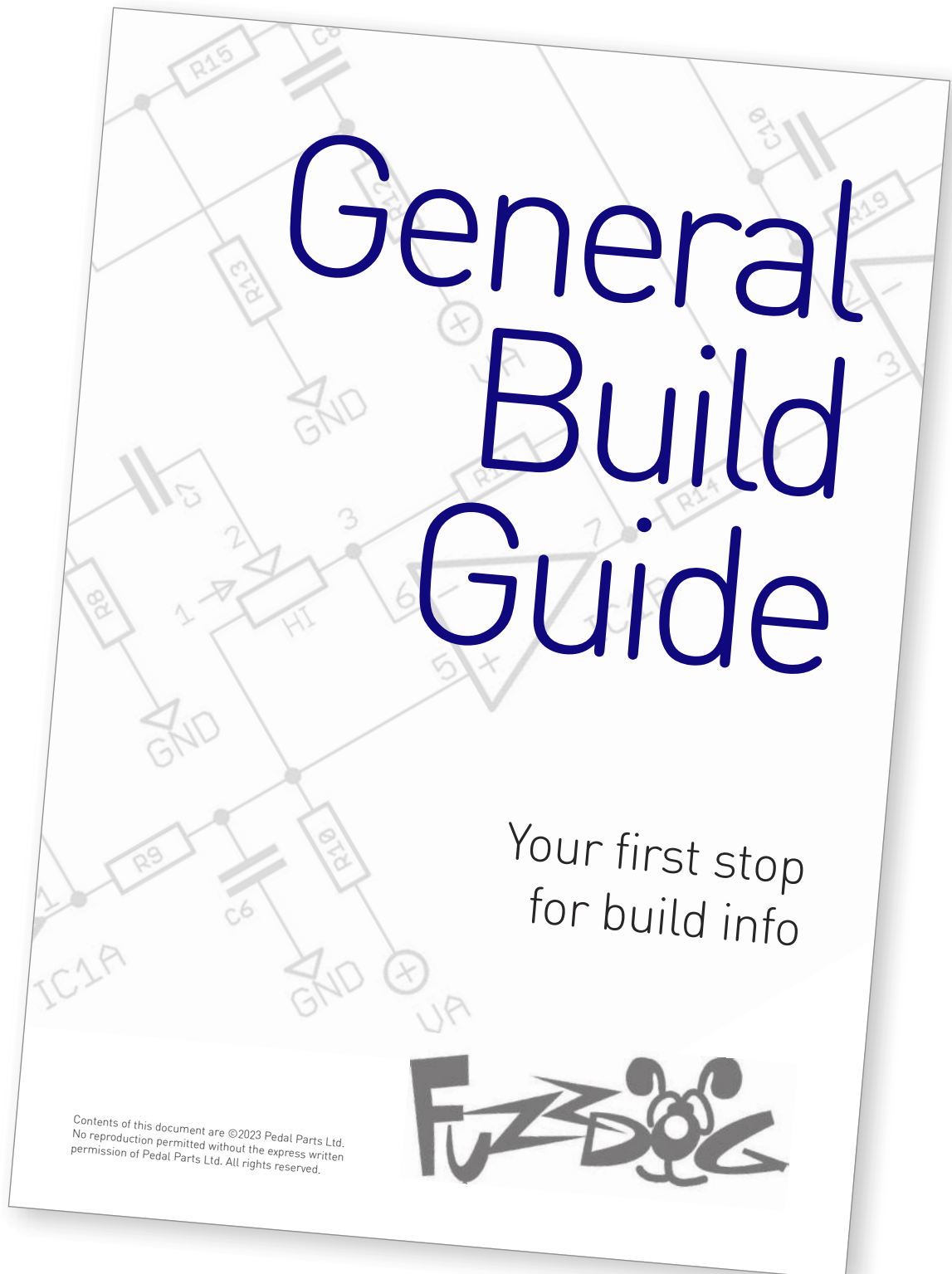

Schematic + BOM

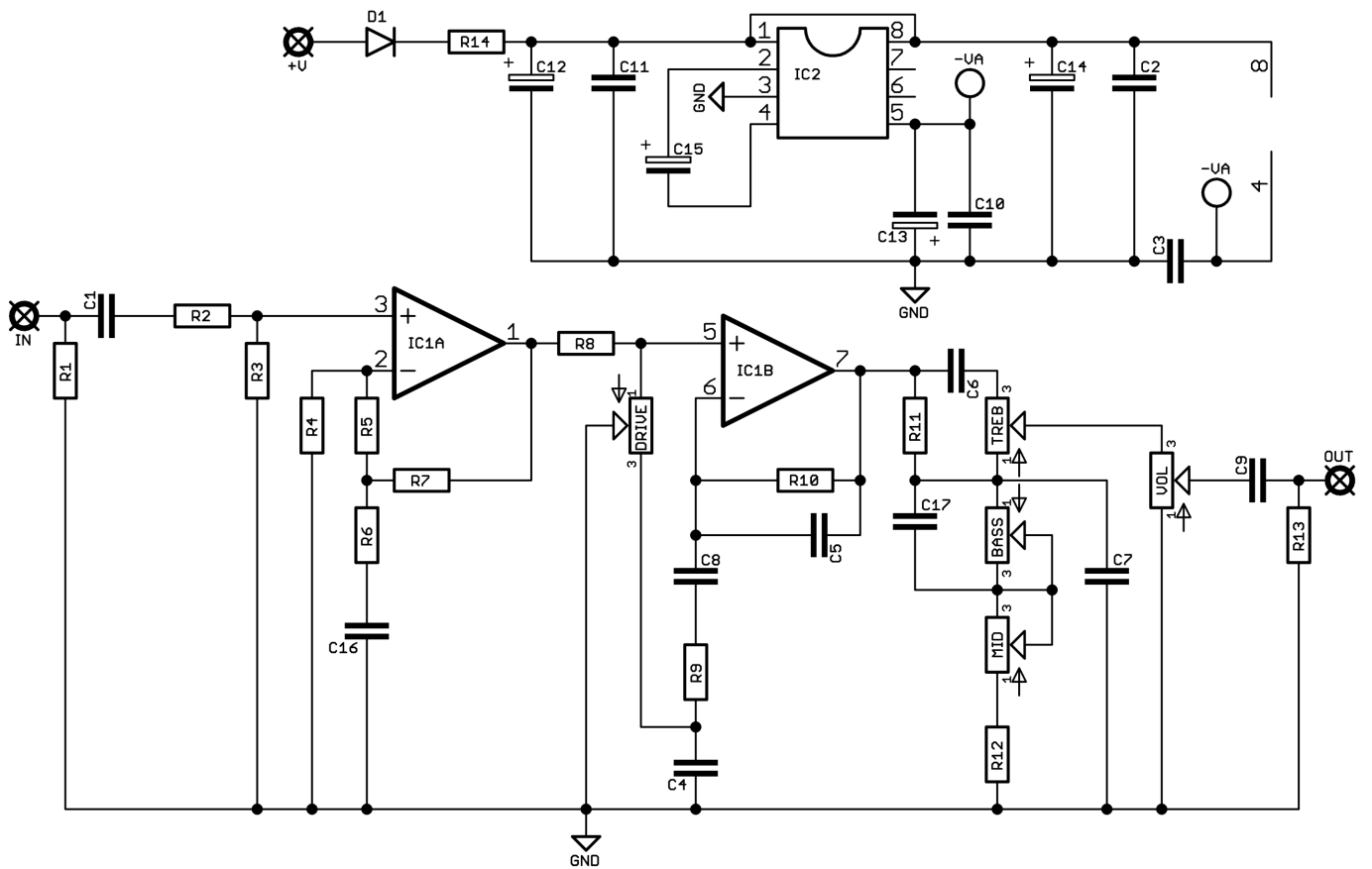

| | | | | | |
|-----|------|-----|-----------|-------|-----------------|
| R1 | 2M2 | C1 | 100n | D1 | 1N5817 |
| R2 | 33K | C2 | 10n | IC1 | 4558 |
| R3 | 330K | C3 | 10n | IC2 | 7660SEPA/LT1054 |
| R4 | 10K | C4 | 10n | BASS | 25KB |
| R5 | 10K | C5 | 220p | DRIVE | 25KB |
| R6 | 2K7 | C6 | 2n2 | MID | 5KB |
| R7 | 47K | C7 | 22n | TREB | 25KB |
| R8 | 10K | C8 | 2u2 | VOL | 1MB |
| R9 | 68R | C9 | 1u | | |
| R10 | 100K | C10 | 470n | | |
| R11 | 10K | C11 | 100n | | |
| R12 | 820R | C12 | 100u elec | | |
| R13 | 47K | C13 | 100u elec | | |
| R14 | 100R | C14 | 100u elec | | |
| | | C15 | 10u elec | | |
| | | C16 | 22n | | |
| | | C17 | 220n | | |

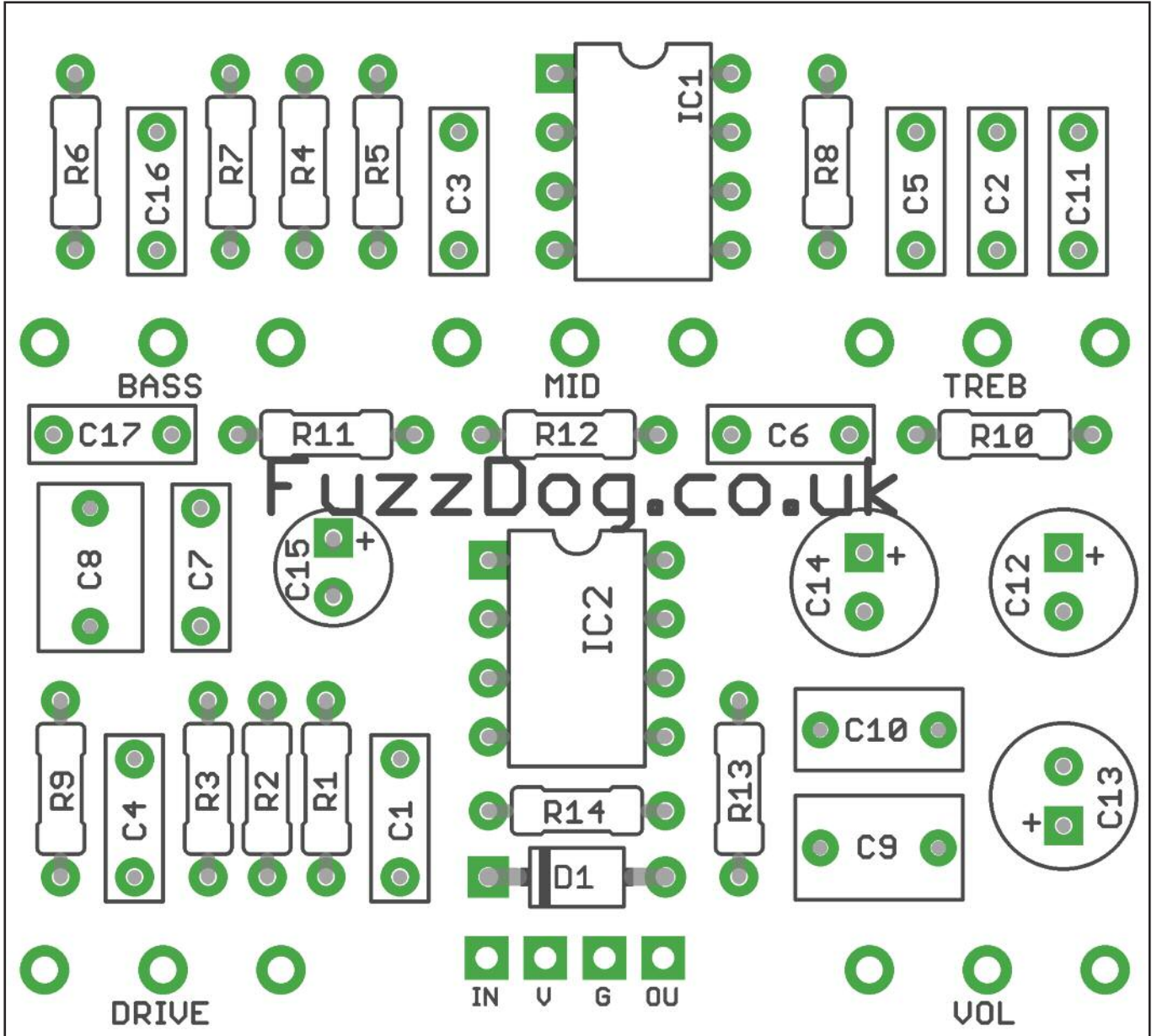

Snap the small metal tags off the pots so they can be mounted flush in the box.

You should solder all other board-mounted components before you solder the pots.

Once they're in place you'll have no access to much of the board.

WARNING

With the gain and treble dimed this will squeal unless it's in a buffered chain.

Drilling template

Hammond 1590B - 60 x 111 x 31mm

Drill sizes listed are minimum.

It's a good idea to add 1mm to anything mounted on the PCB that'll poke through the front of the enclosure.

Drill sizes:

| | |
|-----------------|------|
| Pots | 7mm |
| Jacks | 10mm |
| Footswitch | 12mm |
| DC Socket | 12mm |
| Toggle switches | 6mm |
| Rotary switches | 10mm |

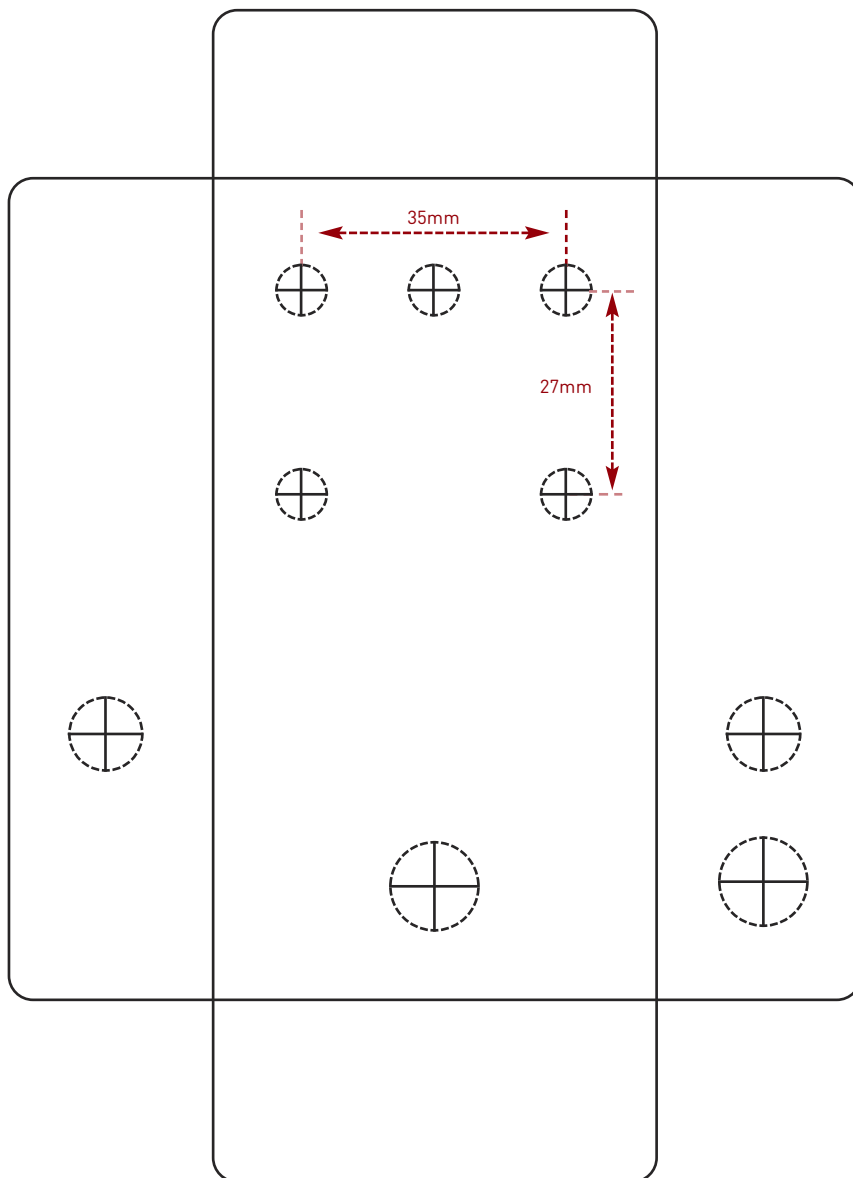

This template is a rough guide only. You should ensure correct marking of your enclosure before drilling. You use this template at your own risk.

Pedal Parts Ltd can accept no responsibility for incorrect drilling of enclosures.

FuzzDog.co.uk