

# Supreaux Bolt v2

Boutique 18V version of the  
ROG Supro Amp Tone Shaper

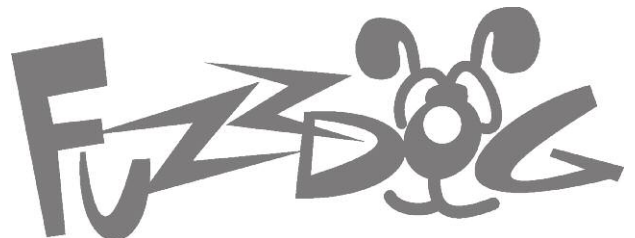

# Important notes

## If you're using any of our footswitch daughterboards, DOWNLOAD THE DAUGHTERBOARD DOCUMENT

- Download and read the appropriate build document for the daughterboard as well as this one BEFORE you start.
- DO NOT solder the supplied Current Limiting Resistor (CLR) to the main circuit board even if there is a place for it. This should be soldered to the footswitch daughterboard.

## POWER SUPPLY

Unless otherwise stated in this document this circuit is designed to be powered with 9V DC.

## COMPONENT SPECS

Unless otherwise stated in this document:

- Resistors should be 0.25W. You can use those with higher ratings but check the physical size of them.
- Electrolytics caps should be at least 25V for 9V circuits, 35V for 18V circuits. Again, check physical size if using higher ratings.

## LAYOUT CONVENTIONS

Unless otherwise stated in this document, the following are used:

- **Electrolytic capacitors:**  
Long leg (anode) to square pad.
- **Diodes:**  
Striped leg (cathode) to square pad.
- **ICs:**  
Square pad indicates pin 1.

# Schematic + BOM

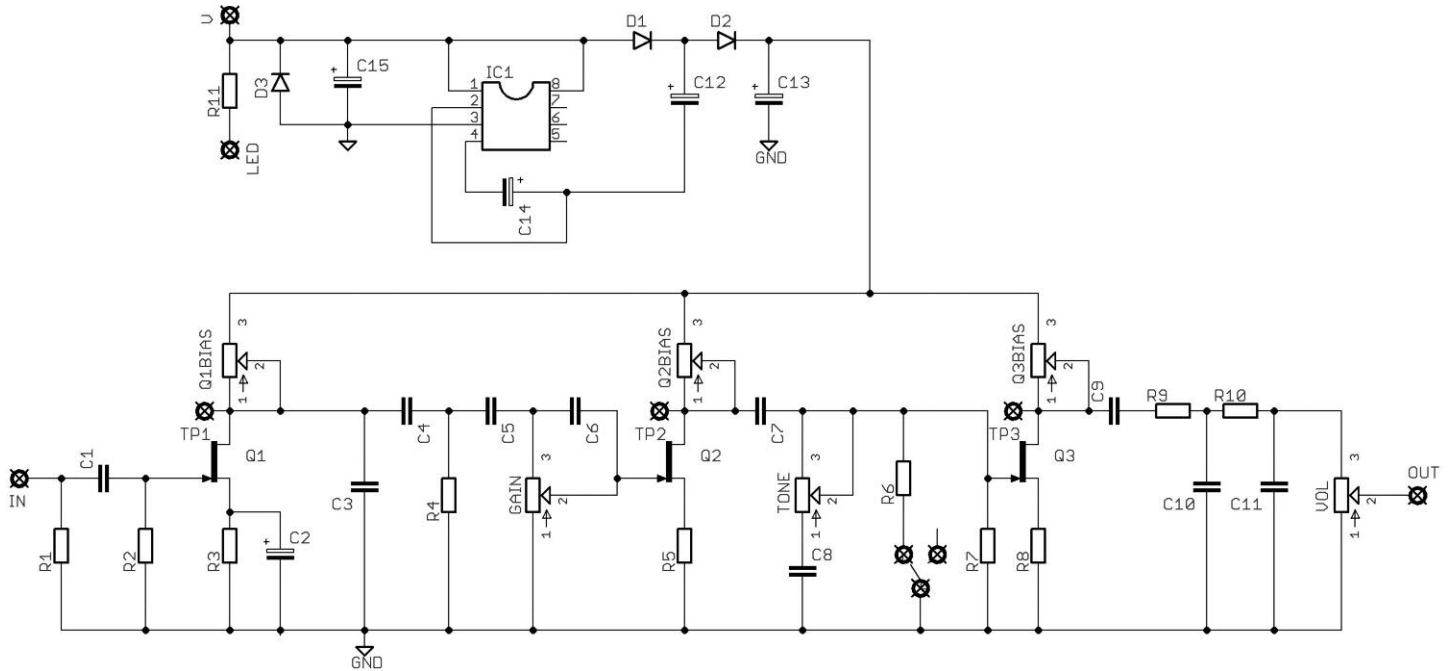

R1	1M	C1	22n	Q1,2	J201*
R2	1M	C2	33u elec	Q3	2N5457*
R3	1K5	C3	470p	IC1	7660S
R4	470K	C4	4n7	D1,2	1N4148
R5	2K7	C5	4n7	D3	1N4001
R6	120K	C6	470p	TONE	500KA
R7	470K	C7	10n	VOL	100KA
R8	220R	C8	4n7	GAIN	500KA
R9	12K	C9	10n	T1,2,3	100K Trim
R10	12K	C10	3n3	SWITCH	SPDT ON-ON
		C11	3n3		
		C12	10u elec		
		C13	10u elec		
		C14	10u elec		
		C15	100u elec		

Parts listed in blue are for the 18V charge pump. If you want to run the circuit at 9V like the RunOffGroove original, or use an 18V supply, leave these out and check the notes later in the document for jumper placement.

\*We've included pads so you can use the SMT versions of these FETs if you prefer.

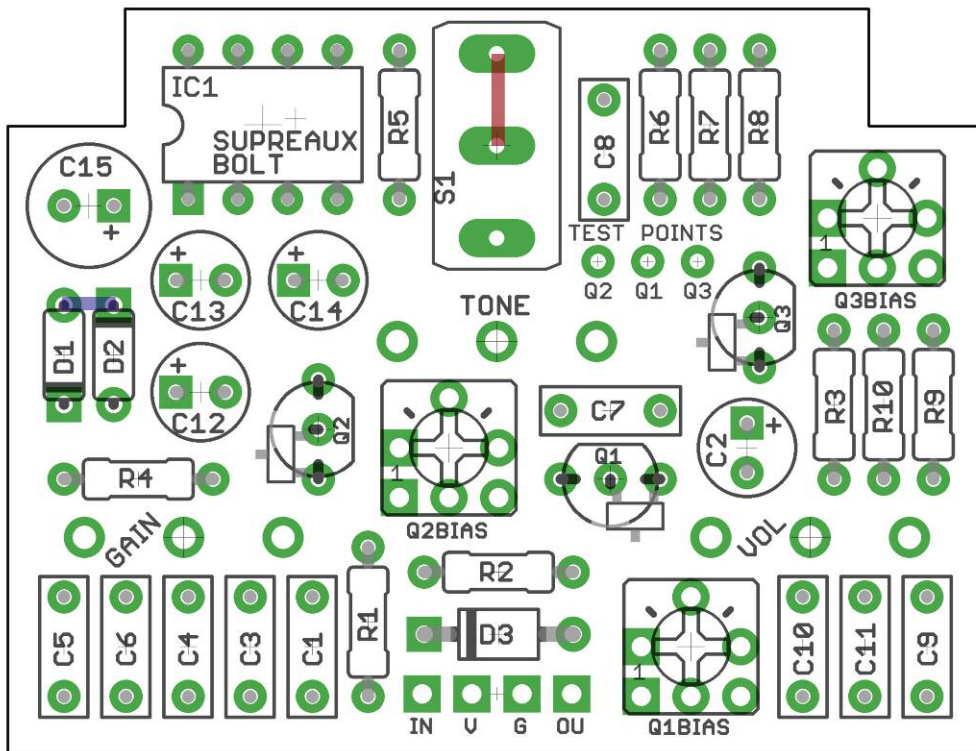

PCB layout ©2018 Pedal Parts Ltd.

The power and signal pads on the PCB conform to the FuzzDog Direct Connection format, so can be paired with the appropriate daughterboard for quick and easy offboard wiring.

Be very careful when soldering the diodes, LED and transistors. They're very sensitive to heat. You should use some kind of heat sink (crocodile clip or reverse action tweezers) on each leg as you solder them. Keep exposure to heat to a minimum (under 2 seconds).

It's best to use a socket for the IC.

Snap the small metal tag off the pots so they can be mounted flush in the box.

Pot mounts on the back side of the board. You can use vertical-mount pots or just wire up 'normal' ones. It's a good idea to place the pots in their holes in the enclosure when you're soldering them in place on the PCB. That way you know they're going to line up ok. Best way to do it is to solder a single pin of each pot in place, then do a visual check to see that they're all sitting at the same height. If not, melt the joints and readjust any that are off.

Similarly, for the toggle switch it's best to solder a single lug then check it for position. If not straight or flat, melt the joint and reposition before soldering the other two lugs.

If your pots don't have protective plastic covers you should place a strip of thick card between them and the board when soldering to keep them a good distance from the pcb to avoid shorting other components.

You should solder all other board-mounted components before you solder the pots. Once they're in place you'll have no access to much of the underside of the board.

To make a circuit more like the original RunOffGroove Supreaux, omit the toggle switch and add a jumper as shown in red above. Leave out all the charge pump components as detailed on page 2, and place a jumper across D1-2 as shown in blue above.

To run the circuit from an 18V supply rather than the charge pump, leave all the pump components out and add the jumper shown in blue above.





# BIASING

Once assembled, power up the circuit and adjust the trimmers to bias the FETS correctly. Test points (T1-3) have been added to the PCB to make this easier.

Set your multimeter for DC Voltage, 20V range. Connect your negative test lead to any ground point.

Now, check what your supply voltage is by putting your positive test lead on the cathode of D2 (circled in red below).

You now need to adjust your trim pots to get half that supply voltage on each test point. So, if you're getting a supply reading of 18V, you should be looking for a 9V reading on your test points.

Place your positive test lead on test point Q1, then adjust trimmer Q1BIAS until you get the correct voltage reading. Repeat the process with pads Q2/Q2BIAS and Q3/Q3BIAS. The EXACT voltage isn't imperative. Around half way is fine.

That's it. You're ready to go.

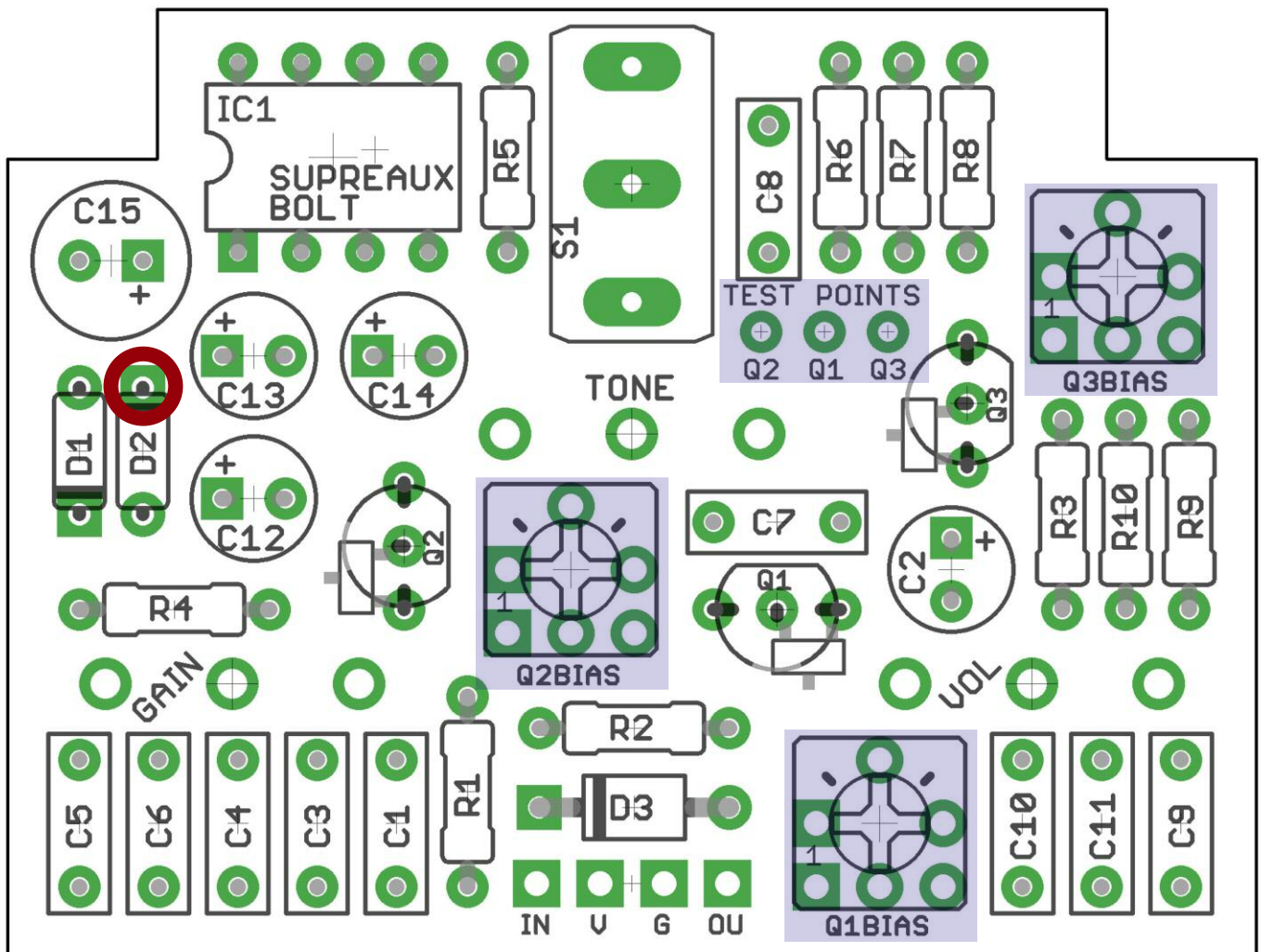

# Test the board!

**Check the relevant daughterboard document for more info before you undertake this stage.**

**UNDER NO CIRCUMSTANCES will troubleshooting help be offered if you have skipped this stage. No exceptions.**

Once you've finished the circuit it makes sense to test it before starting on the switch and LED wiring. It'll cut down troubleshooting time in the long run. If the circuit works at this stage, but it doesn't once you wire up the switch - guess what? You've probably made a mistake with the switch.

Solder some nice, long lengths of wire to the board connections for 9V, GND, IN and OUT. Connect IN and OUT to the jacks as shown. Connect all the GNDs together (twist them up and add a small amount of solder to tack it). Connect the battery + lead to the 9V wire, same method. Plug in. Go!

If you're using a ribbon cable you can tack the wires to the ends of that. It's a lot easier to take them off there than it is to desolder wires from the PCB pads.

If it works, carry on and do your switch wiring. If not... aw man. At least you know the problem is with the circuit. Find out why, get it working, THEN worry about the switch etc.

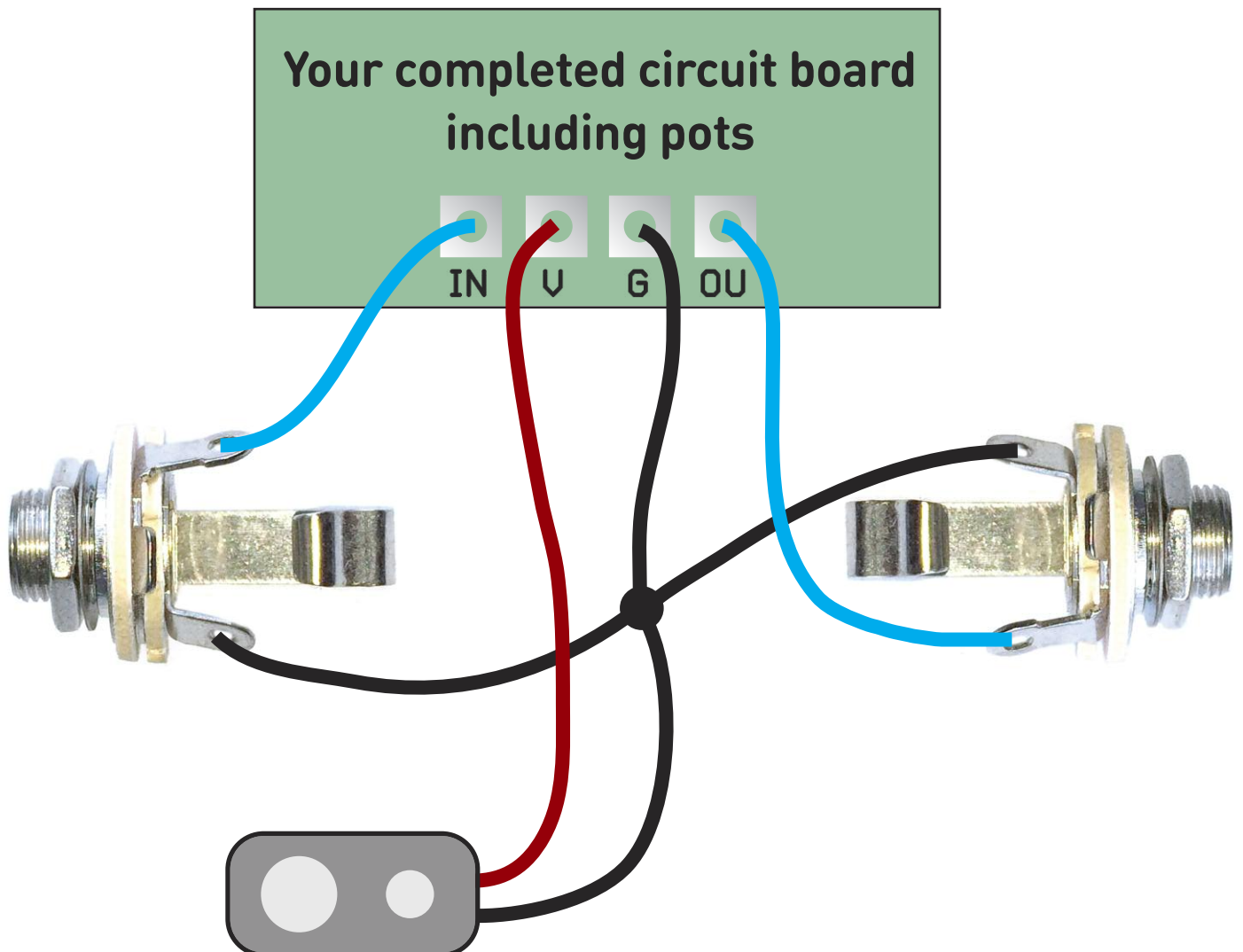

# Wire it up (if using a daughterboard please refer to the relevant document)

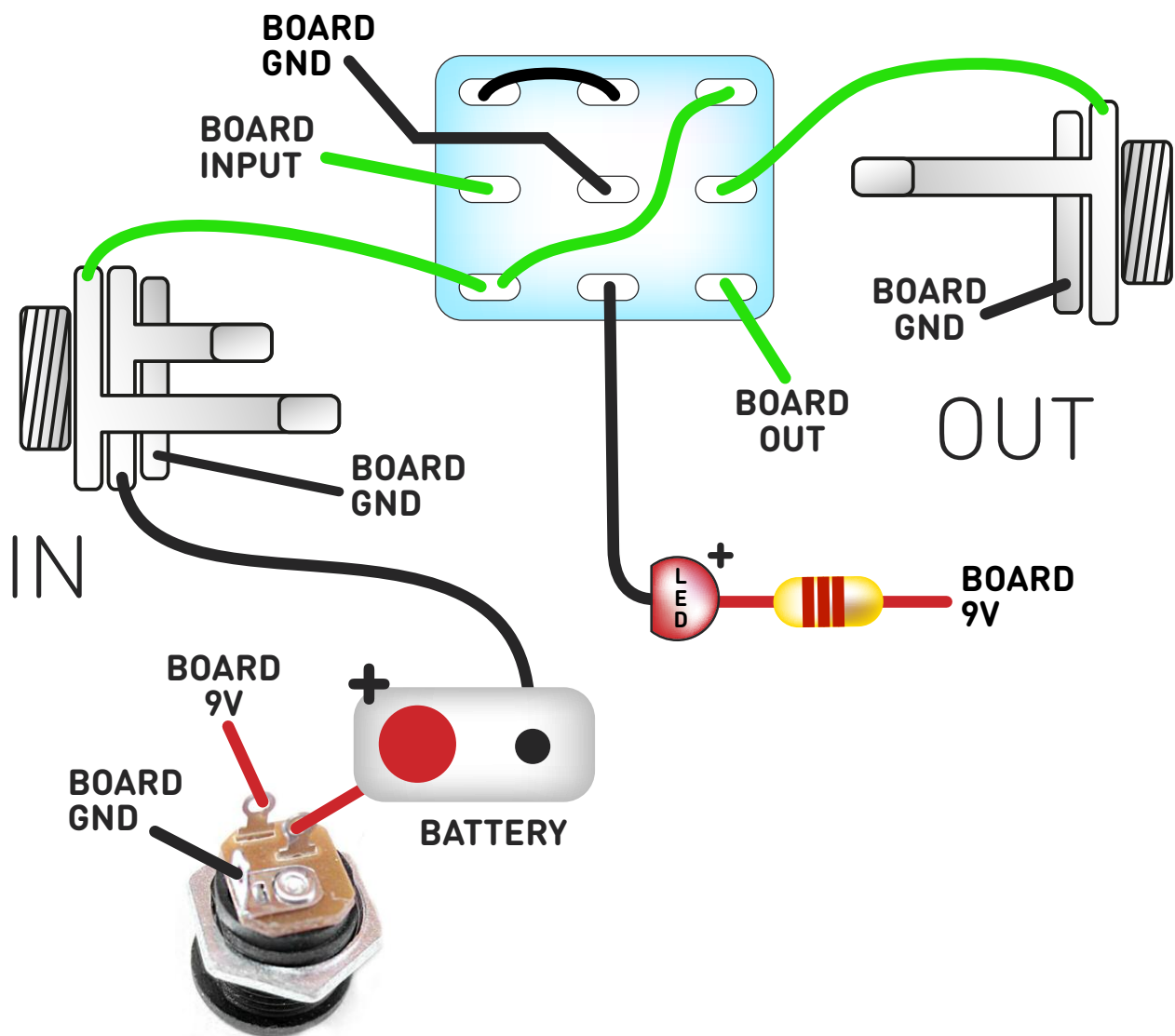

Wiring shown above will disconnect the battery when you remove the jack plug from the input, and also when a DC plug is inserted.

The Board GND connections don't all have to directly attach to the board. You can run a couple of wires from the DC connector, one to the board, another to the IN jack, then daisy chain that over to the OUT jack.

It doesn't matter how they all connect, as long as they do.

This circuit is standard, Negative GND. Your power supply should be Tip Negative / Sleeve Positive. That's the same as your standard pedals (Boss etc), and you can safely daisy-chain your supply to this pedal.

# Drilling template

Hammond 1590B  
60 x 111 x 31mm

Recommended drill sizes:

Pots	7mm
Jacks	10mm
Footswitch	12mm
DC Socket	12mm
Toggle Switch	6mm

It's a good idea to drill the potholes 1mm bigger if you're board-mounting them.  
Wiggle room = good!

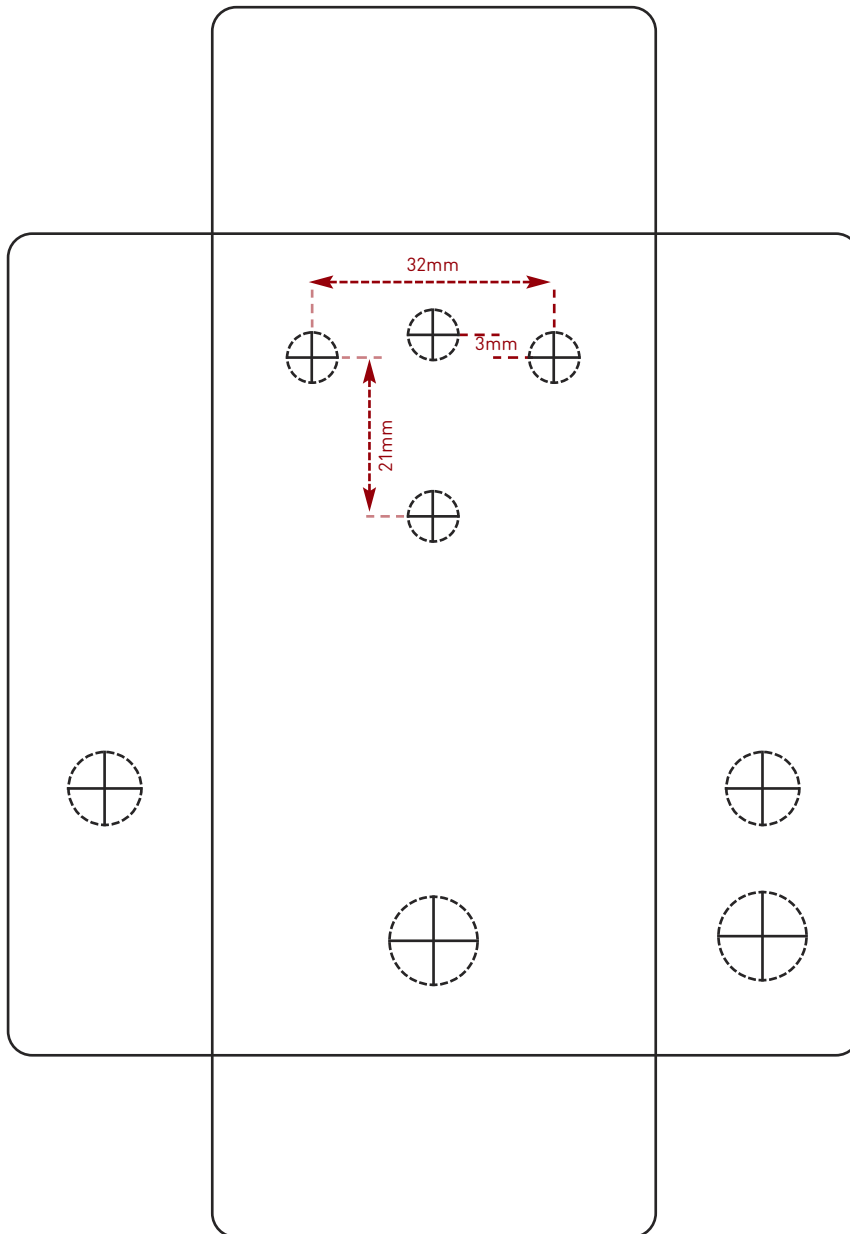

This template is a rough guide only. You should ensure correct marking of your enclosure before drilling. You use this template at your own risk.  
Pedal Parts Ltd can accept no responsibility for incorrect drilling of enclosures.

FuzzDog.co.uk