

Pink Plexi

Marshall tone in a purple box,
not pink. That'd be silly.

Schematic +BOM

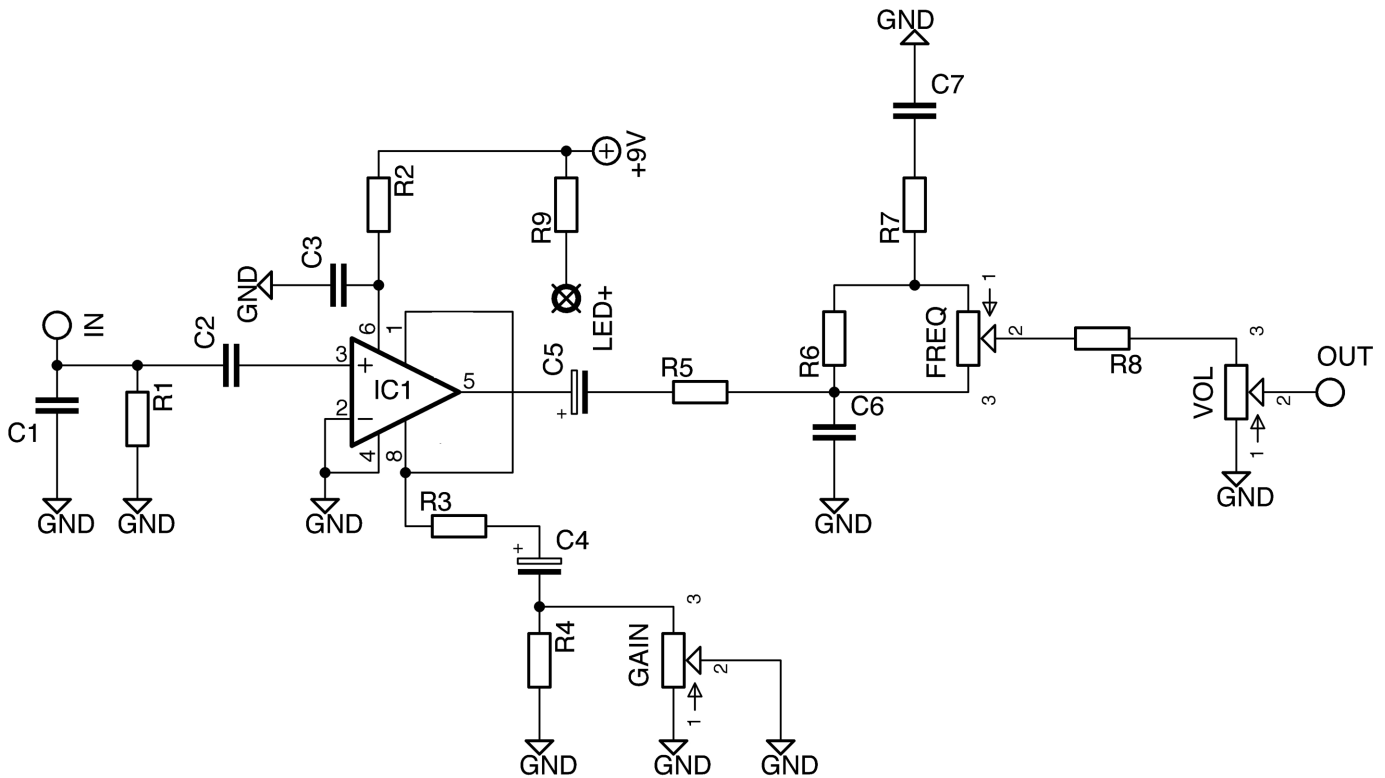

R1	2M2
R2	10R
R3	10R
R4	470R
R5	4K7
R6	4K7
R7	1K8
R8	330R
R9	2K2 (CLR)

C1	390p
C2	4n7
C3	100n
C4	47u
C5	47u
C6	4n7
C7	100n
C8	100u elec**

GAIN	1KB*
FREQ	5KB
VOL	100KB

IC	LM386
----	-------

*Gain control is pretty much all or nothing. This is down to the original design. It can be helped a little by using a 1KC pot if you can find one.

**C8 is a power smoothing cap not in the original circuit. Though not shown on the schematic, it connects between 9V and GND.

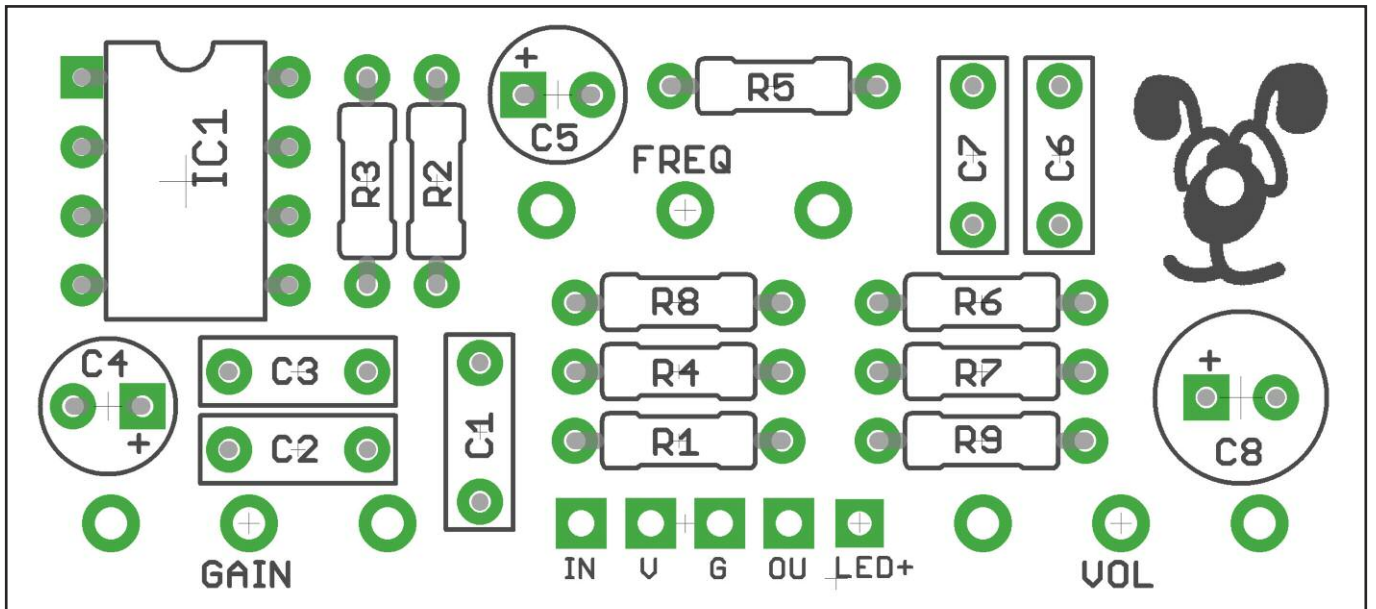

General Notes

The power and signal pads on the PCB conform to the FuzzDog Direct Connection format, so can be paired with the appropriate daughterboard for quick and easy offboard wiring. Check the separate daughterboard document for details.

Be very careful when soldering the LED. They're very sensitive to heat. You should use some kind of heat sink (crocodile clip or reverse action tweezers) on each leg as you solder them. Keep exposure to heat to a minimum (under 2 seconds). You should use a socket for the IC, or be super careful not to overheat. Take your time.

Snap the small metal tag off the pots so they can be mounted flush in the box.

Positive (anode) leg of the electrolytic capacitors go into the square pads.

Pots mount on the back side of the board. You can use vertical-mount pots or just wire up 'normal' ones. It's a good idea to place the pots in their holes in the enclosure when you're soldering them in place on the PCB. That way you know they're going to line up ok. Best way to do it is to solder a single pin of each pot in place, then do a visual check to see that they're all sitting at the same height. If not, melt the joints and readjust any that are off.

If your pots don't have protective plastic covers you should place a strip of thick card between them and the board when soldering to keep them a good distance from the PCB to avoid shorting other components.

You should solder all other board-mounted components before you solder the pots. Once they're in place you'll have no access to much of the underside of the board.

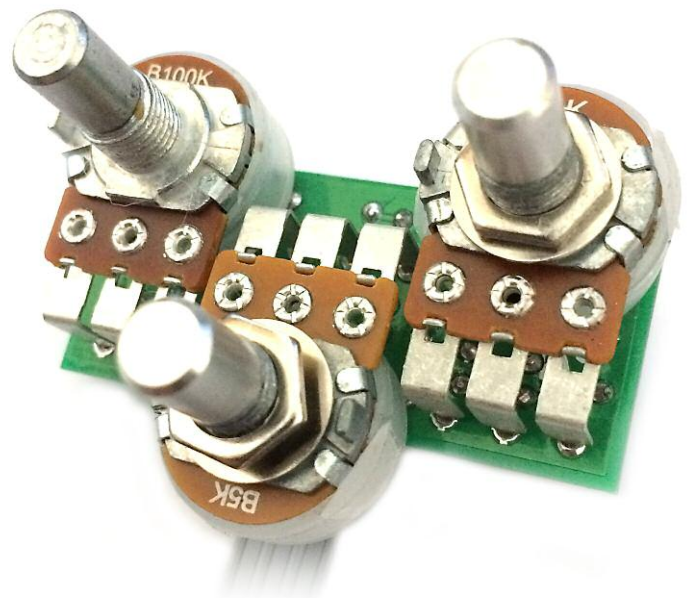

Test the board!

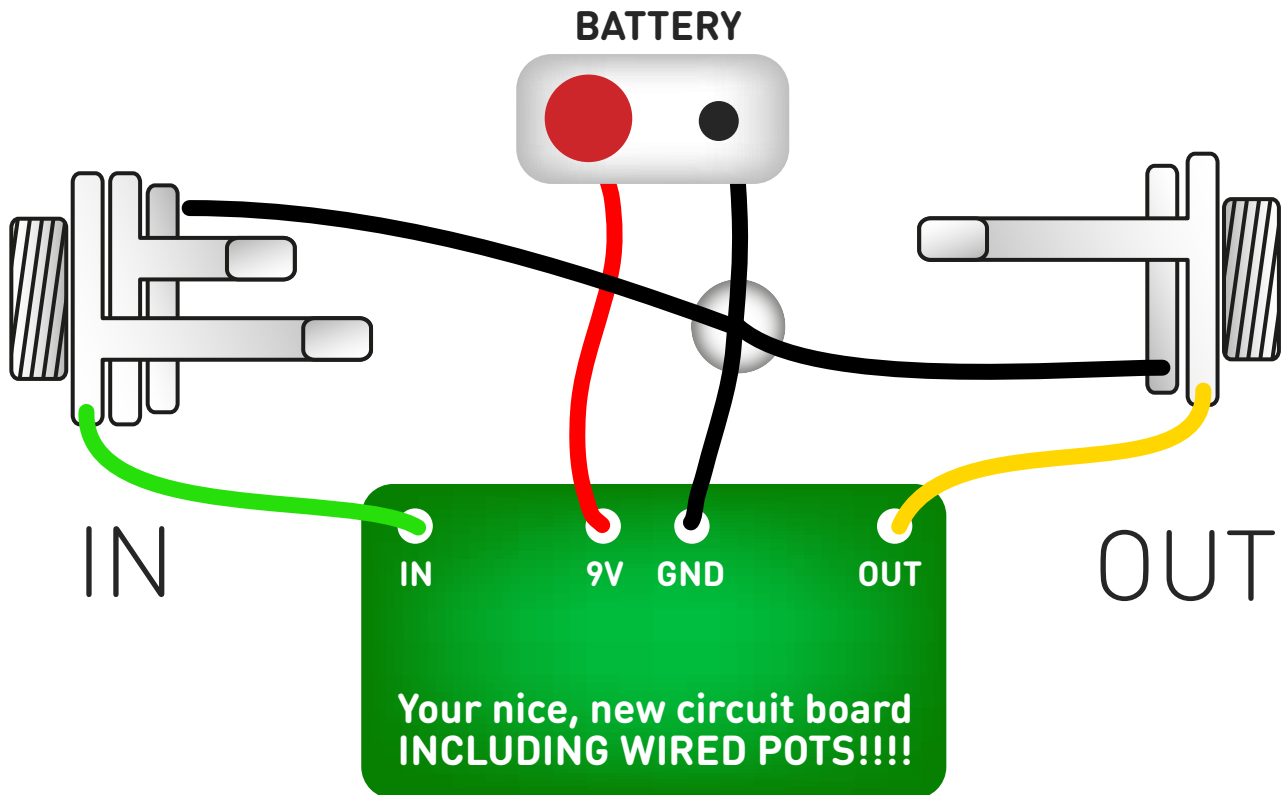

UNDER NO CIRCUMSTANCES will troubleshooting help be offered if you have skipped this stage. No exceptions.

Battery clip is supplied to test the circuit. Power supply is recommended when using the finished delay as it will EAT batteries.

Once you've finished the circuit it makes sense to test it before starting on the switch and LED wiring. It'll cut down troubleshooting time in the long run. If the circuit works at this stage, but it doesn't once you wire up the switch - guess what? You've probably made a mistake with the switch.

Solder some nice, long lengths of wire to the board connections for 9V, GND, IN and OUT. Connect IN and OUT to the jacks as shown. Connect all the GNDs together (twist them up and add a small amount of solder to tack it). Connect the battery + lead to the 9V wire, same method. Plug in. Go!

If it works, crack on and do your switch wiring. If not... aw man. At least you know the problem is with the circuit. Find out why, get it working, THEN worry about the switch etc.

Wire it up - with battery

(if using a daughterboard please refer to the relevant document)

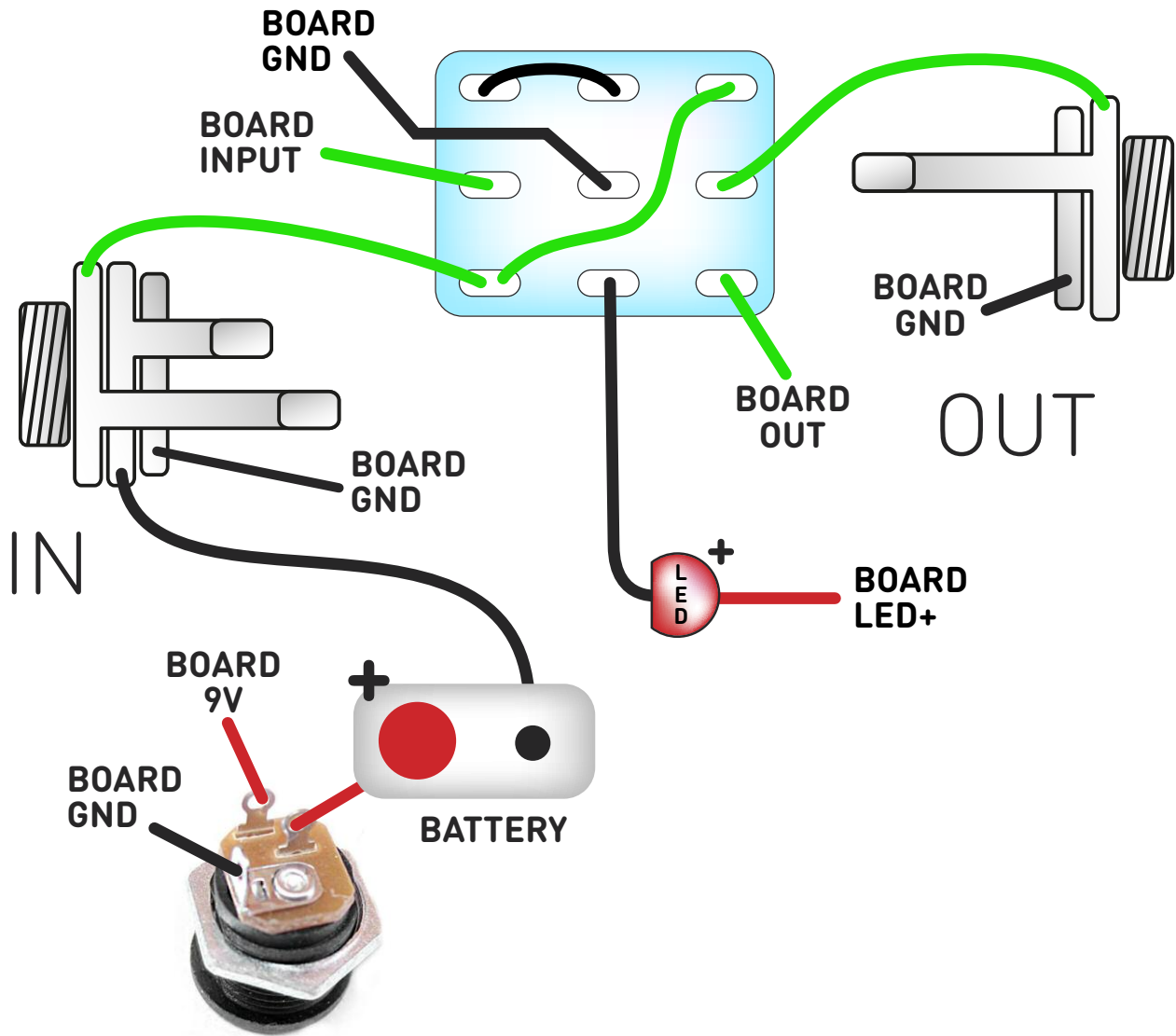

This circuit is standard, Negative GND. Your power supply should be Tip Negative / Sleeve Positive. That's the same as your standard pedals (Boss etc), and you can safely daisy-chain your supply to this pedal.

The BOARD GND connections don't all have to connect to one point. They can be daisy-chained around the circuit, using larger connection points (such as jack socket lugs) for multiple connections. As long as they all connect together in some way.

Wire it up - DC only version

(if using a daughterboard please refer to the relevant document)

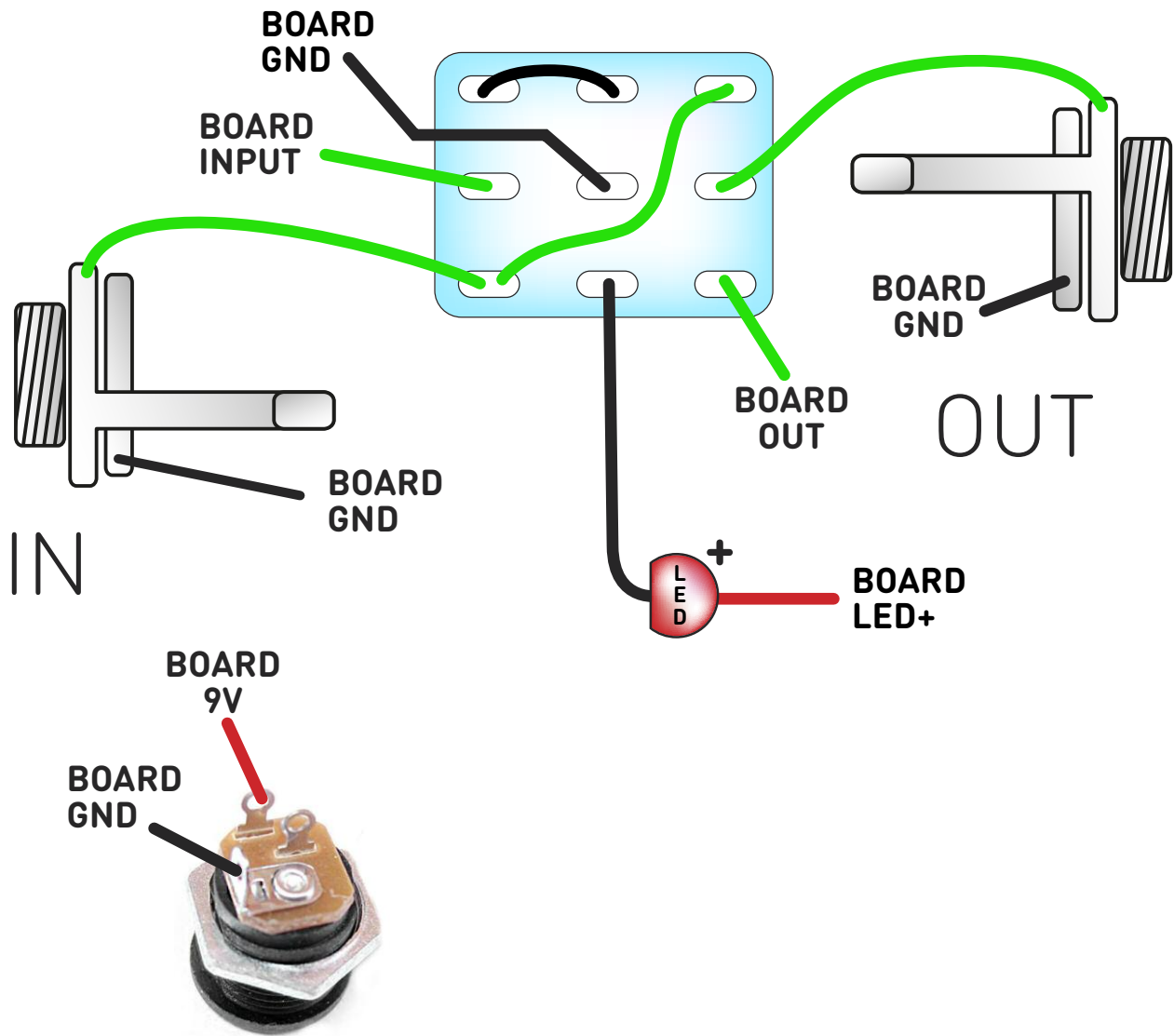

This circuit is standard, Negative GND. Your power supply should be Tip Negative / Sleeve Positive. That's the same as your standard pedals (Boss etc), and you can safely daisy-chain your supply to this pedal.

The BOARD GND connections don't all have to connect to one point. They can be daisy-chained around the circuit, using larger connection points (such as jack socket lugs) for multiple connections. As long as they all connect together in some way.

Drilling template

Hammond 1590B
60 x 111 x 31mm

Recommended drill sizes:

Pots	7mm
Jacks	10mm
Footswitch	12mm
DC Socket	12mm

It's a good idea to drill the holes for the pots 1mm bigger to give yourself some wiggle room, unless you're a drill ninja.

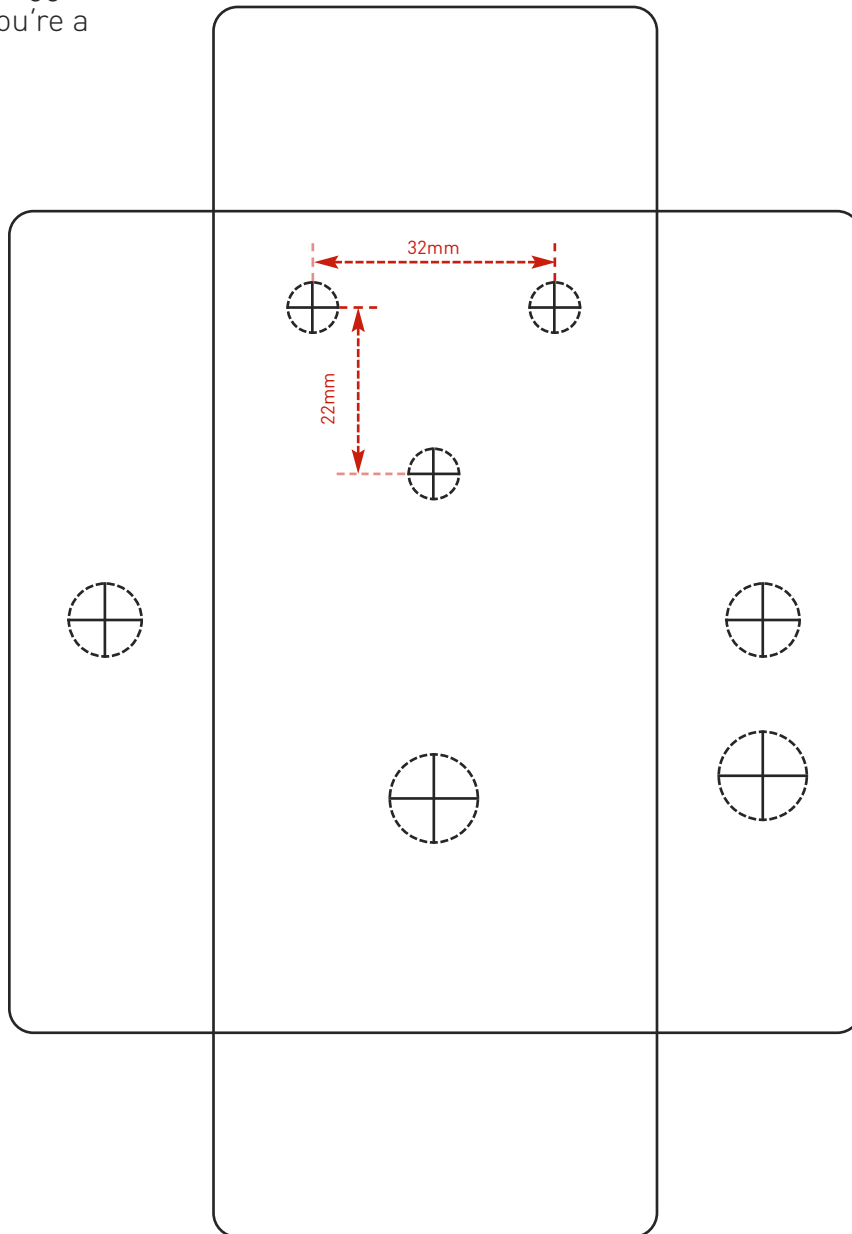

This template is a rough guide only. You should ensure correct marking of your enclosure before drilling. You use this template at your own risk. Pedal Parts Ltd can accept no responsibility for incorrect drilling of enclosures.

PedalParts.co.uk