

# Mini Model T

Emulating a Sunn Pre-Amp  
for Doomy heaven



# Important notes

## If you're using any of our footswitch daughterboards, DOWNLOAD THE DAUGHTERBOARD DOCUMENT

- Download and read the appropriate build document for the daughterboard as well as this one BEFORE you start.
- DO NOT solder the supplied Current Limiting Resistor (CLR) to the main circuit board even if there is a place for it. This should be soldered to the footswitch daughterboard.

## POWER SUPPLY

Unless otherwise stated in this document this circuit is designed to be powered with 9V DC.

## COMPONENT SPECS

Unless otherwise stated in this document:

- Resistors should be 0.25W. You can use those with higher ratings but check the physical size of them.
- Electrolytics caps should be at least 25V for 9V circuits, 35V for 18V circuits. Again, check physical size if using higher ratings.

## LAYOUT CONVENTIONS

Unless otherwise stated in this document, the following are used:

- **Electrolytic capacitors:**  
Long leg (anode) to square pad.
- **Diodes/LEDs:**  
Striped leg (cathode) to square pad. Short leg to square pad for LEDs.
- **ICs:**  
Square pad indicates pin 1.

# Schematic + BOM

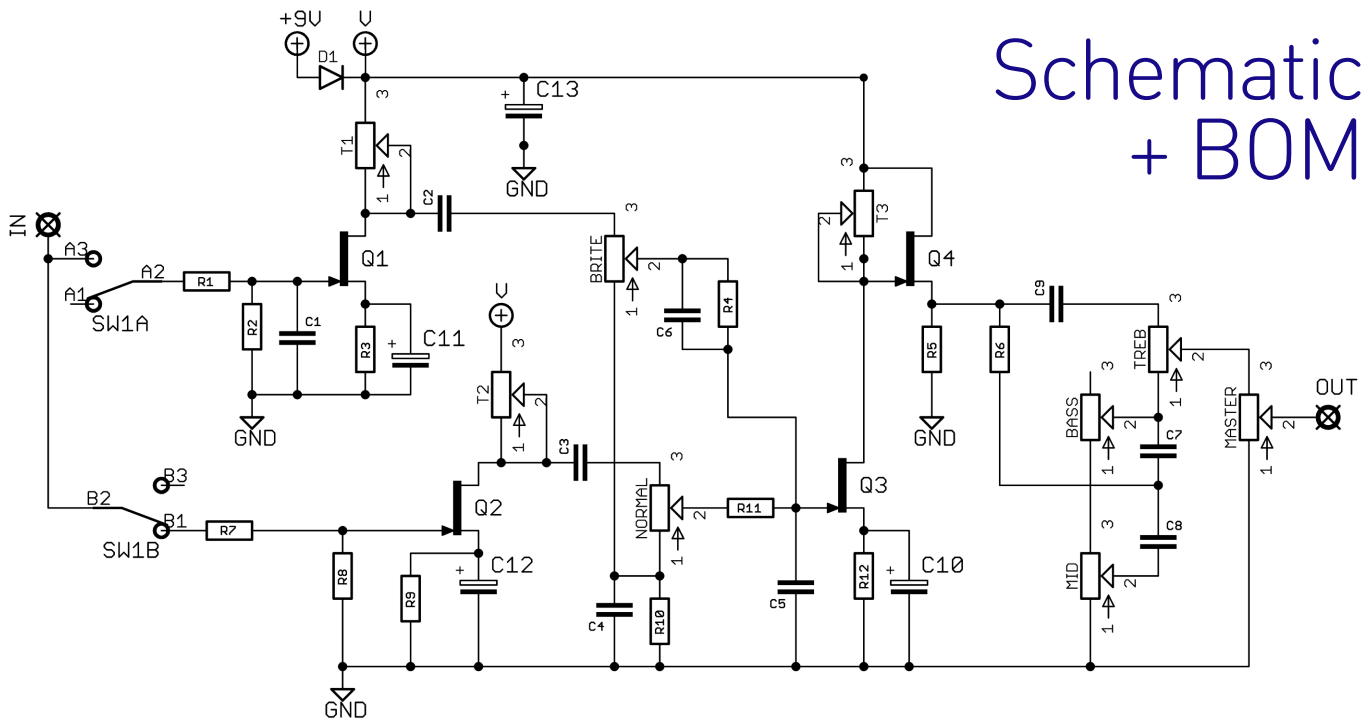

R1	68K	C1	220p	Q1-4	J201*
R2	1M	C2	22n	D1	1N5817
R3	680R	C3	22n	BASS	1MB
R4	150K	C4	270p	BRITE	1MA
R5	47K	C5	220p	MAST	100KA
R6	56K	C6	470p	MID	25KB
R7	68K	C7	22n	NORM	1MA
R8	1M	C8	22n	TREB	250KB
R9	680R	C9	270p	T1-3	47-50K trim
R10	100K	C10	22u elec	S1**	DPDT ON-ON-ON
R11	150K	C11	220u elec		
R12	820R	C12	220u elec		
		C13	100u elec		

\*You can use through-hole J201 or SMT MMBFJ201

\*\*You can use a DPDT ON-ON if you only want to switch between the two channels. If you want to have the option of running both in parallel you'll need a DPDT ON-ON-ON. These come in different configurations. You need one with the following connections in the three positions:

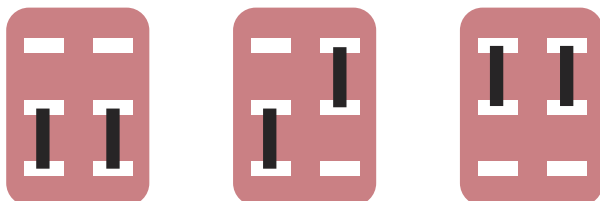

Tayda stock this particular type.

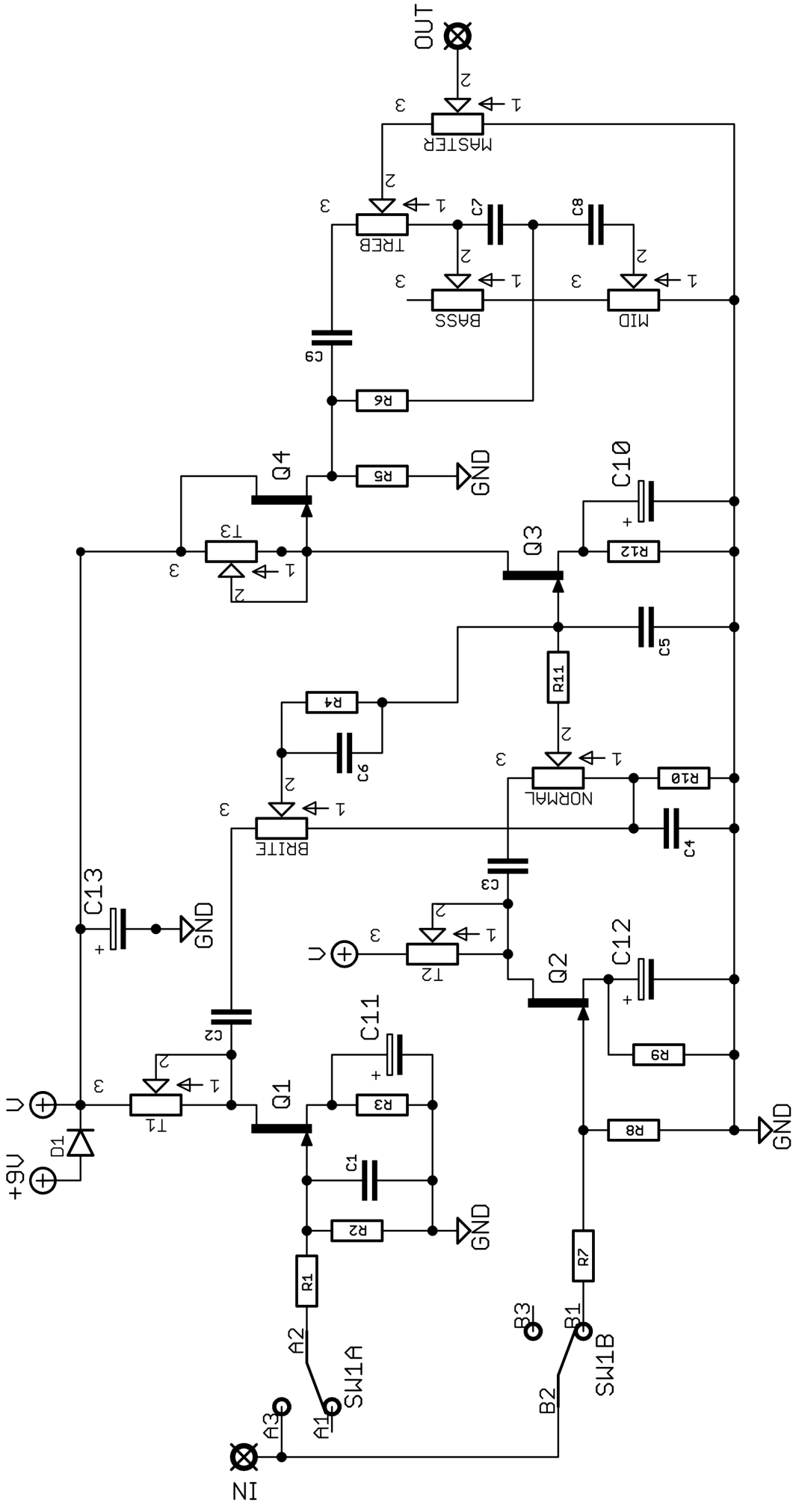

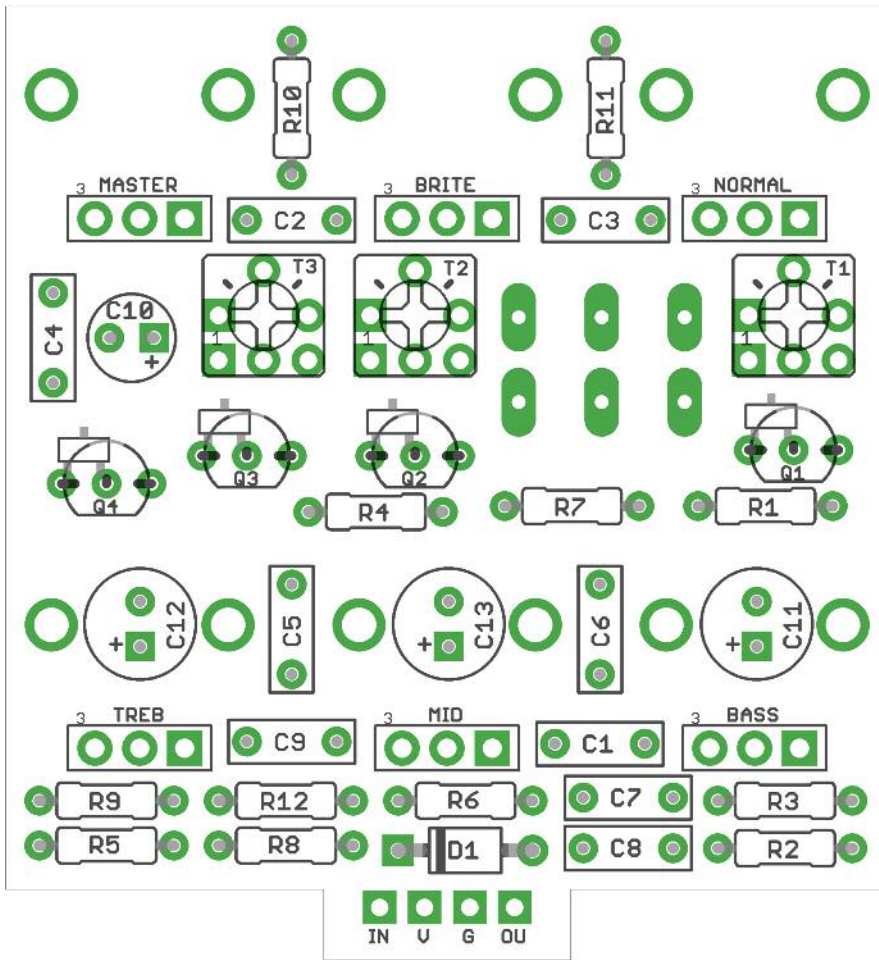

PCB layout ©2022 Pedal Parts Ltd.

The power and signal pads on the PCB conform to the FuzzDog Direct Connection format, so can be paired with the appropriate daughterboard for quick and easy offboard wiring. Check the separate daughterboard document for details.

Be very careful when soldering the FETs and diode. They're very sensitive to heat. Keep exposure to heat to a minimum (under 2 seconds) and leave a few seconds between soldering each leg.

You should solder all other board-mounted components before you solder the pots. Once they're in place you'll have no access to much of the board. Make sure your pots all line up nicely.

The best way to do that is to solder a single pin of each pot in place then melt and adjust if necessary before soldering in the other two pins. Same for the toggle switch. If your pots don't have protective plastic jackets ensure you leave a decent gap between the pot body and the PCB otherwise you risk shorting out the circuit.

Snap the small metal tag off the pots so they can be mounted flush in the box.



# Biassing

Once you have everything soldered up and hooked up for testing (see next page) you need to bias the FETs.

The trimmer numbering ties up with the FET numbering, so T1 adjusts Q1 etc. There's no adjustment for Q4.

Adjust each trimmer until the Drain pin of the corresponding FET measures around 4.5-5V. You'll need a multimeter to do this. Set it to DC Voltage, put your Common probe onto any ground point, and the other probe onto the Drain of the FET being tested. The voltage will increase as you turn the trimmer clockwise.

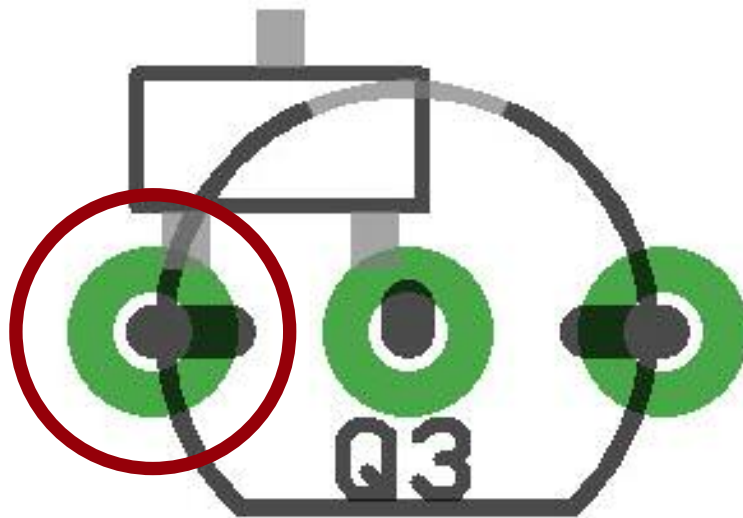

# Testing

You can test the Distortion and Boost sections individually, as if they're separate boards. Do the test wiring as shown below for each section.

**UNDER NO CIRCUMSTANCES will troubleshooting help be offered if you have skipped this stage. No exceptions.**

Solder some nice, long lengths of wire to the board connections for 9V, GND, IN and OUT. Connect IN and OUT to the jacks as shown. Connect all the GNDs together (twist them up and add a small amount of solder to tack it). Connect the battery + lead to the 9V wire, same method. Plug in. Go!

You'll have to connect the wire from pad 02 to either 01 or 03, or you'll get no signal from the Distortion section.

There's no need to connect power to the 0V and 0G pads - these are purely to supply power to an LED if you're adding the Octave footswitch.

If you have a circuit tester (we sell a few!) just use that as normal.

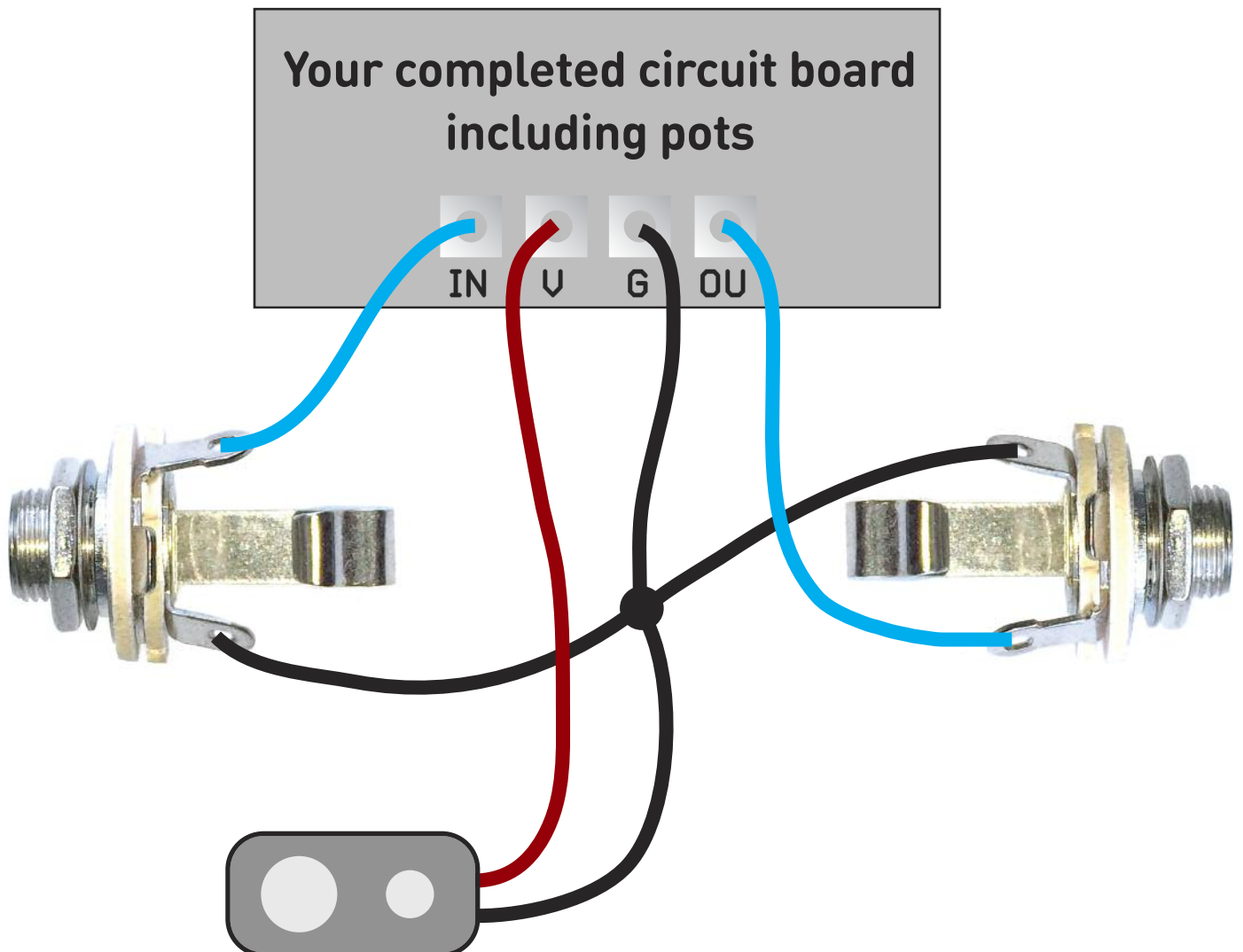

# Wire it up (if using a daughterboard please refer to the relevant document)

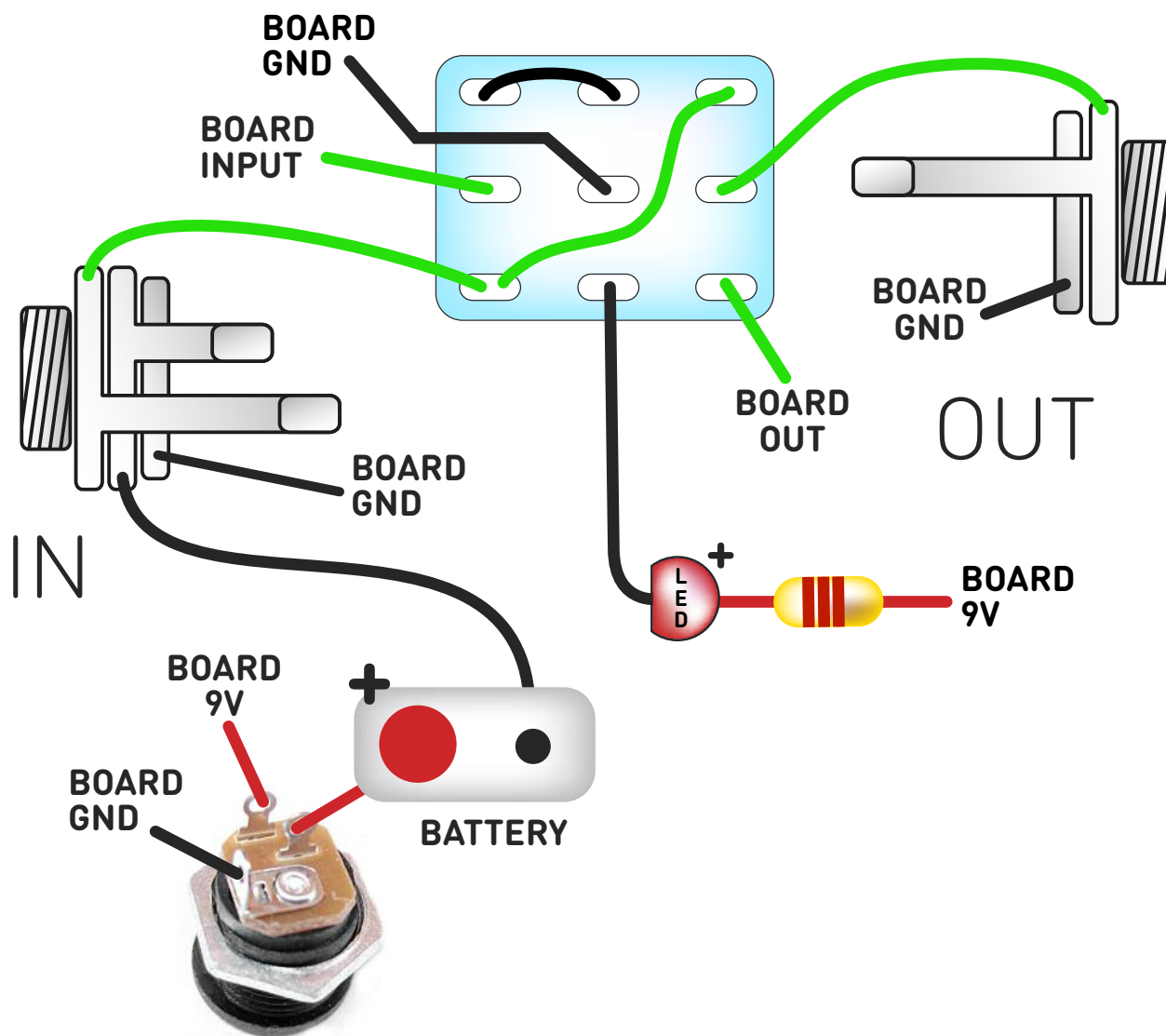

Wiring shown above will disconnect the battery when you remove the jack plug from the input, and also when a DC plug is inserted.

The Board GND connections don't all have to directly attach to the board. You can run a couple of wires from the DC connector, one to the board, another to the IN jack, then daisy chain that over to the OUT jack.

It doesn't matter how they all connect, as long as they do.

This circuit is standard, Negative GND. Your power supply should be Tip Negative / Sleeve Positive. That's the same as your standard pedals (Boss etc), and you can safely daisy-chain your supply to this pedal.



# Drilling template

## Hammond 1590BB

It's a good idea to drill the pot and toggle switch holes 1mm bigger if you're board-mounting them.

Recommended drill sizes:

Pots	7mm
Jacks	10mm
Footswitch	12mm
DC Socket	8/12mm
Toggle switches	6mm

