

# Fuzzy Muff

IC-based Muff Fuzz -  
EHX's early box of gain

[PedalParts.co.uk](http://PedalParts.co.uk)

# Schematic

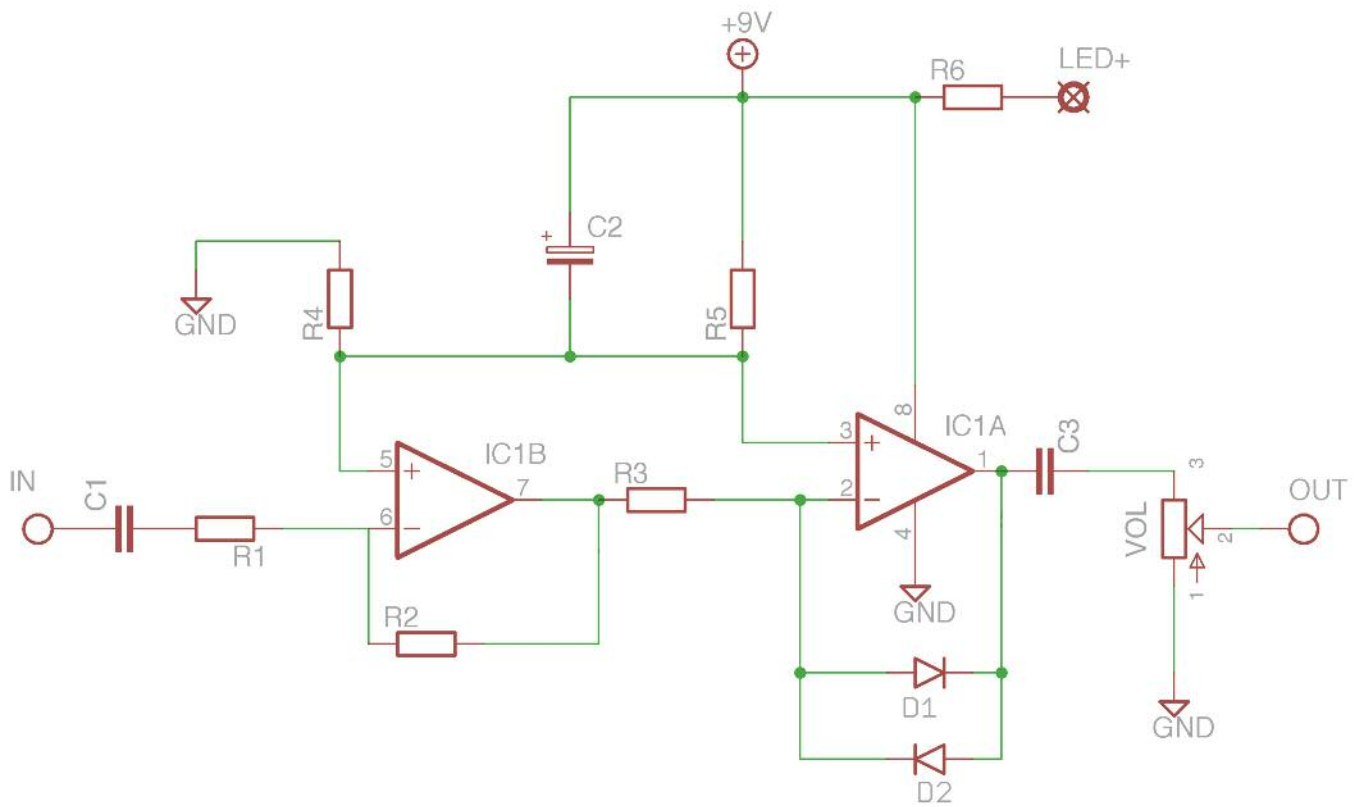

# BOM

R1	100K	C1	10n
R2	470K	C2	10u electrolytic
R3	10K	C3	100n
R4	680K	IC	4558
R5	680K		
R6	2K2 (CLR)		
D1-2	1N34A*	POT	100KA

\*Try whatever diodes you like. Silicon will clip harder.

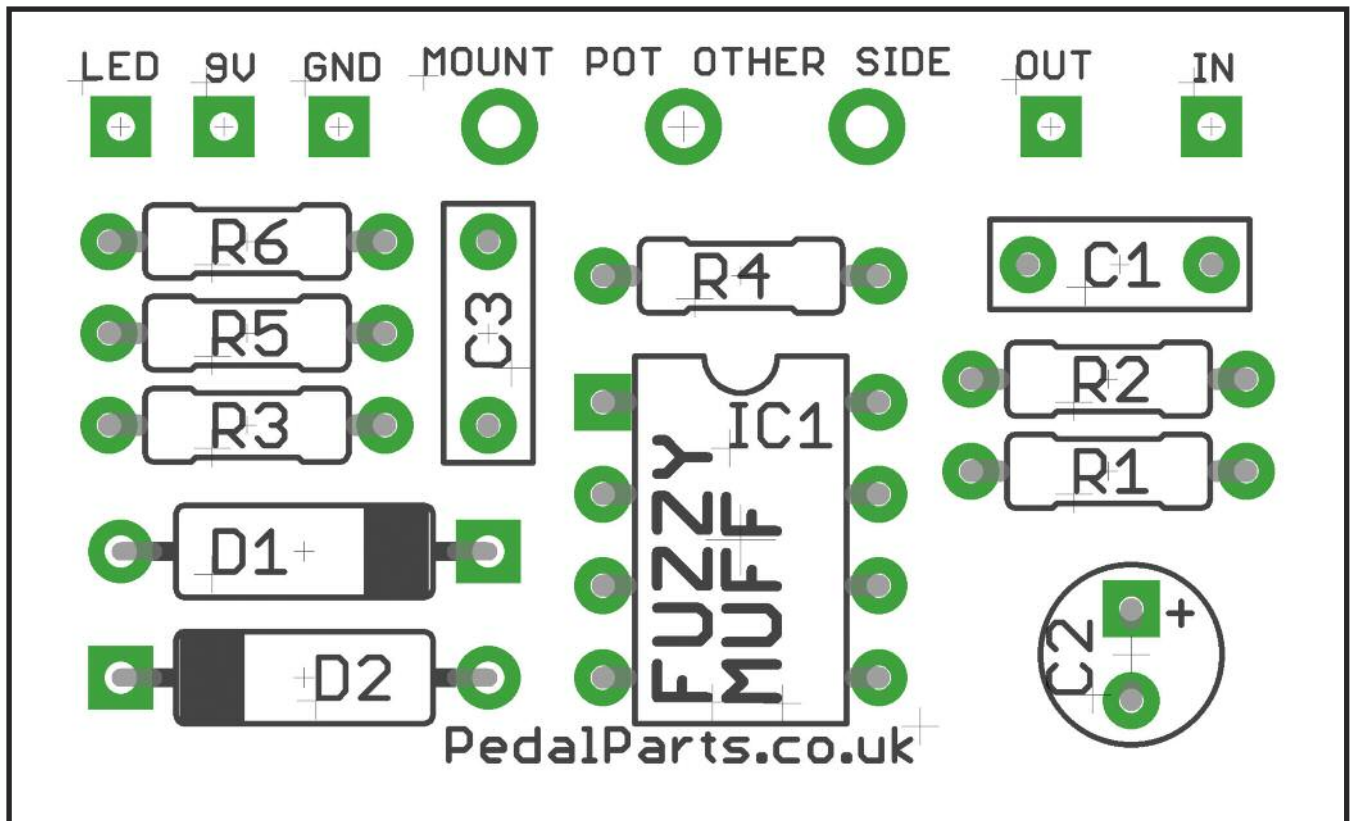

The PCB is designed to have the volume pot mounted directly to it. You can use wire if you like - simply connect the board pads to the corresponding pins on the pot.

Wiring shown overleaf will disconnect the battery when you remove the jack plug from the input, and also when a DC plug is inserted.

Snap the little metal tag off the pot to mount it flush in the box.

Be VERY careful when bending the legs of the 1N34A. The glass case is very fragile and likely to break. Best to hold the leg with some needle-nosed pliers against the case, and bend the leg with your finger so the pliers are taking any strain away from the diode. Always use a heat sink when soldering diodes - they hate heat!

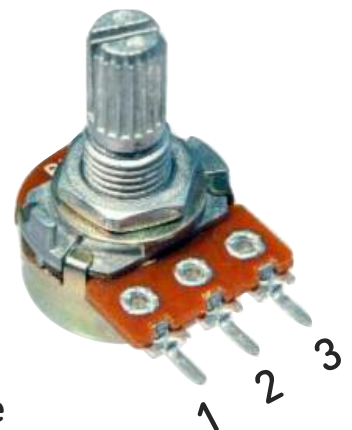

# Test the board!

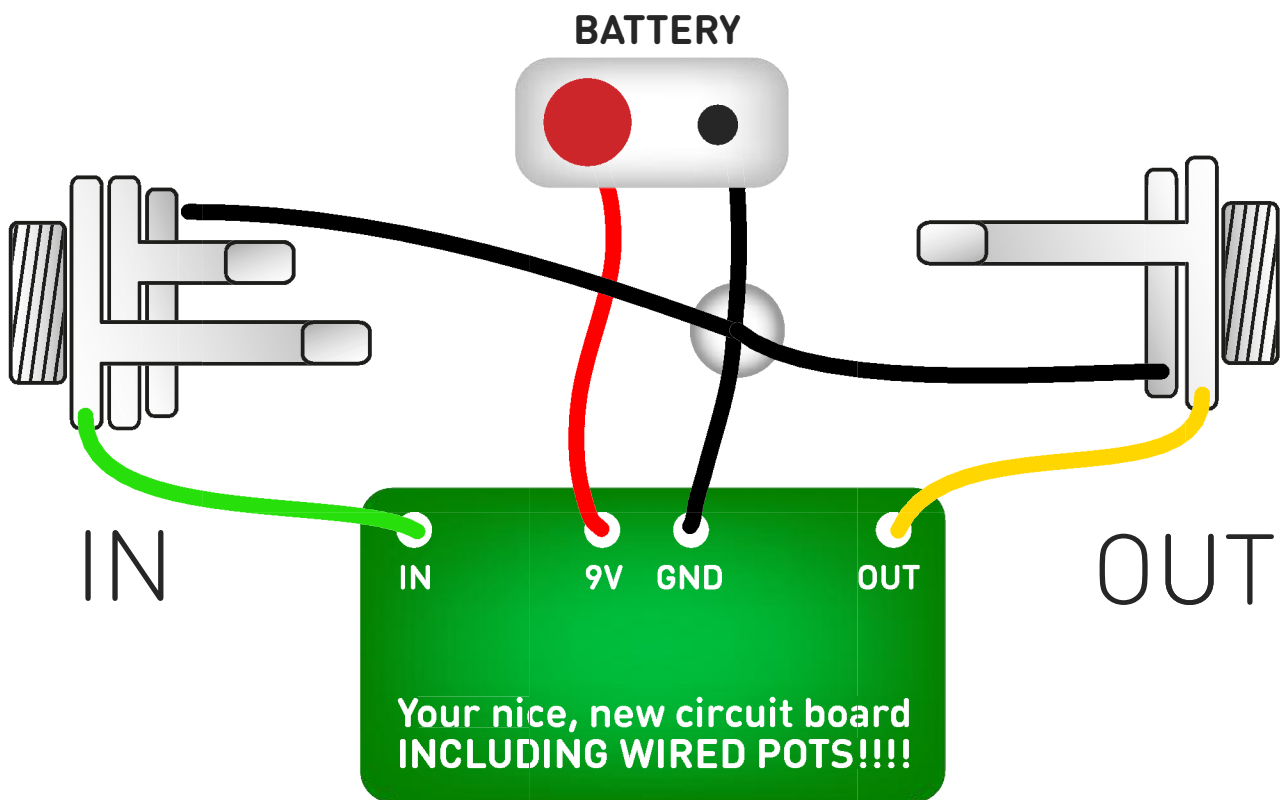

Once you've finished the circuit it makes sense to test it before starting on the switch and LED wiring. It'll cut down troubleshooting time in the long run. If the circuit works at this stage, but it doesn't once you wire up the switch - guess what? You've probably made a mistake with the switch.

Solder some nice, long lengths of wire to the board connections for 9V, GND, IN and OUT. Connect IN and OUT to the jacks as shown. Connect all the GNDs together (twist them up and add a small amount of solder to tack it). Connect the battery + lead to the 9V wire, same method. Plug in. Go!

If it works, crack on and do your switch wiring. If not... aw man. At least you know the problem is with the circuit. Find out why, get it working, THEN worry about the switch etc.

# Wire it up

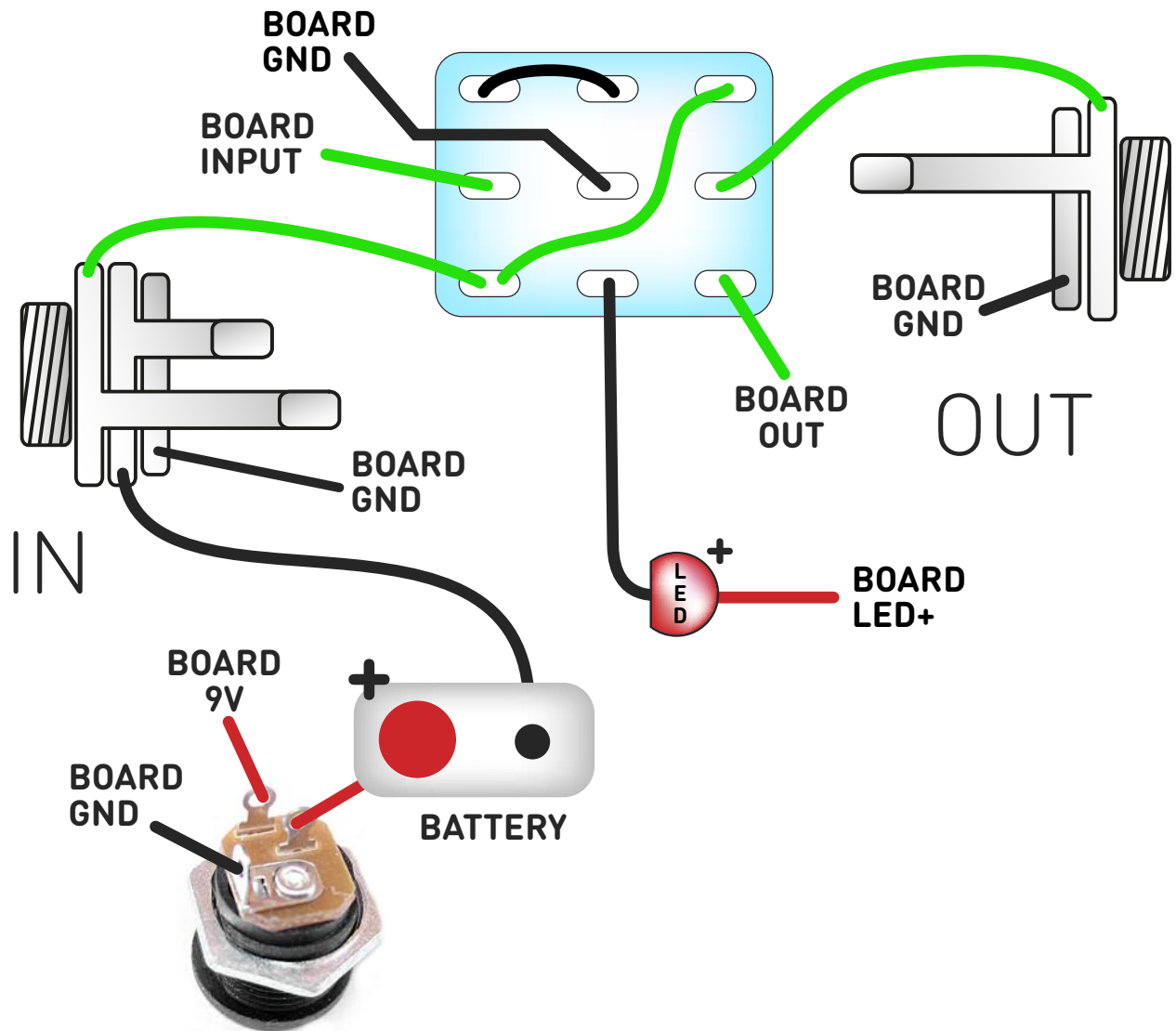

The Board GND connections don't all have to directly attach to the board. You can run a couple of wires from the DC connector, one to the board, another to the IN jack, then daisy chain that over to the OUT jack.

It doesn't matter how they all connect, as long as they do.

This circuit is standard, Negative GND. Your power supply should be Tip Negative / Sleeve Positive. That's the same as your standard pedals (Boss etc), and you can safely daisy-chain your supply to this pedal. Now... get MUFFY!

## PedalParts.co.uk