

Crimson Nipper

Snappy drive with plenty of bite

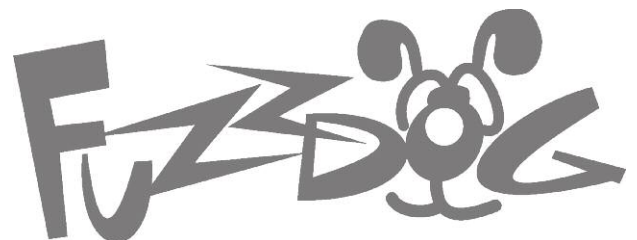

Important notes

If you're using any of our footswitch daughterboards, DOWNLOAD THE DAUGHTERBOARD DOCUMENT

- Download and read the appropriate build document for the daughterboard as well as this one BEFORE you start.
- DO NOT solder the supplied Current Limiting Resistor (CLR) to the main circuit board even if there is a place for it. This should be soldered to the footswitch daughterboard.

POWER SUPPLY

Unless otherwise stated in this document this circuit is designed to be powered with 9V DC.

COMPONENT SPECS

Unless otherwise stated in this document:

- Resistors should be 0.25W. You can use those with higher ratings but check the physical size of them.
- Electrolytics caps should be at least 25V for 9V circuits, 35V for 18V circuits. Again, check physical size if using higher ratings.

LAYOUT CONVENTIONS

Unless otherwise stated in this document, the following are used:

- **Electrolytic capacitors:**
Long leg (anode) to square pad.
- **Diodes/LEDs:**
Striped leg (cathode) to square pad. Short leg to square pad for LEDs.
- **ICs:**
Square pad indicates pin 1.

Schematic + BOM

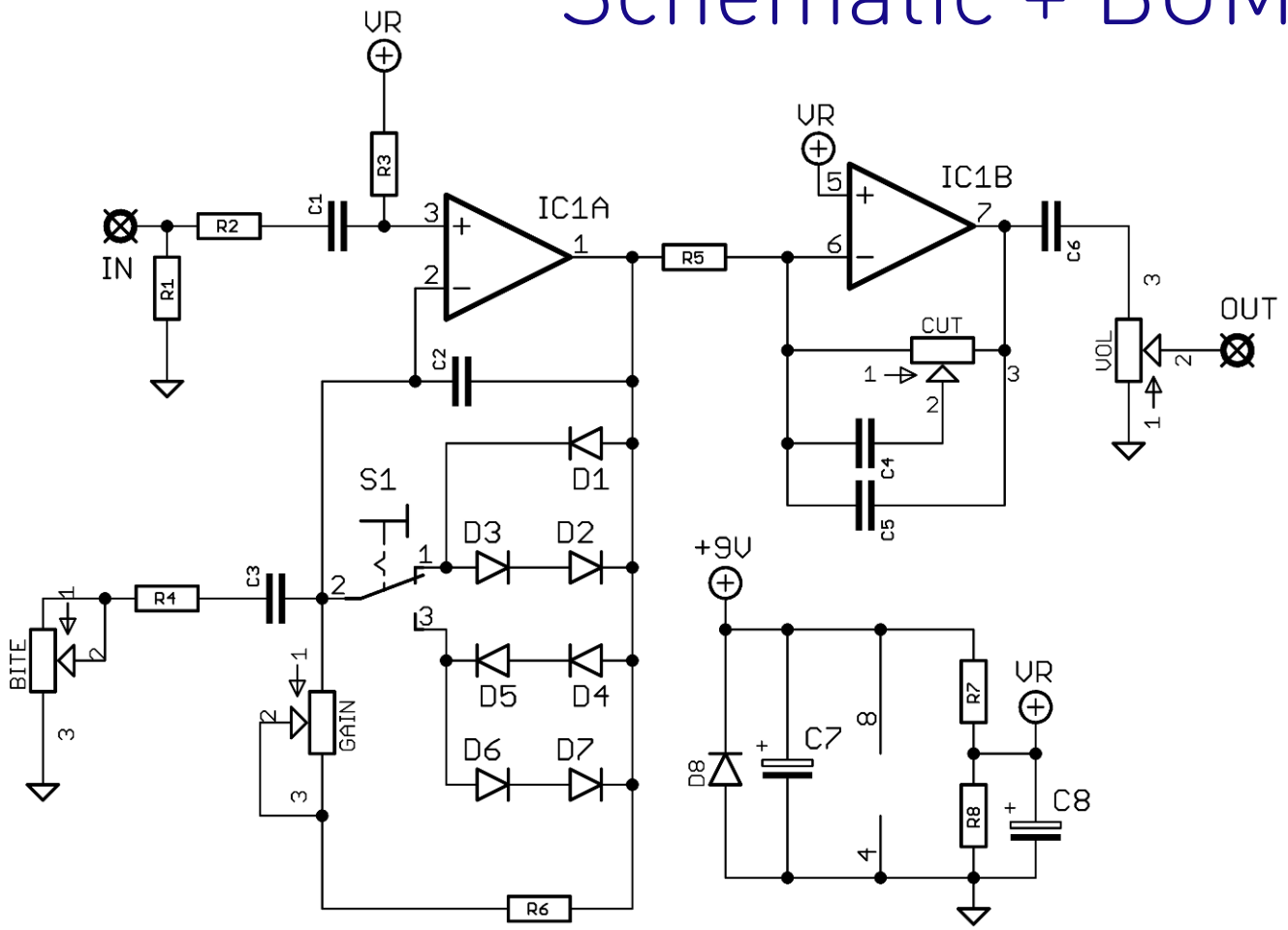

R1	1M	C1	22n	D1-3	1N4148
R2	1K	C2	100p	D4-7	Your choice*
R3	1M	C3	47n	D8	1N4001
R4	1K	C4	10n	IC1	4558
R5	6K8	C5	1n	BITE	25KB
R6	10K	C6	100n	CUT	25KB
R7	10K	C7	100u elec	GAIN	1MA
R8	10K	C8	100u elec	VOL	250KB**
		S1	See next page		

*There are extra spots for a second set of clipping diodes. Try whatever you like in any configuration. If you are adding this option you'll need to put a SPDT toggle switch in S1.

**Original is linear, but log will work better.

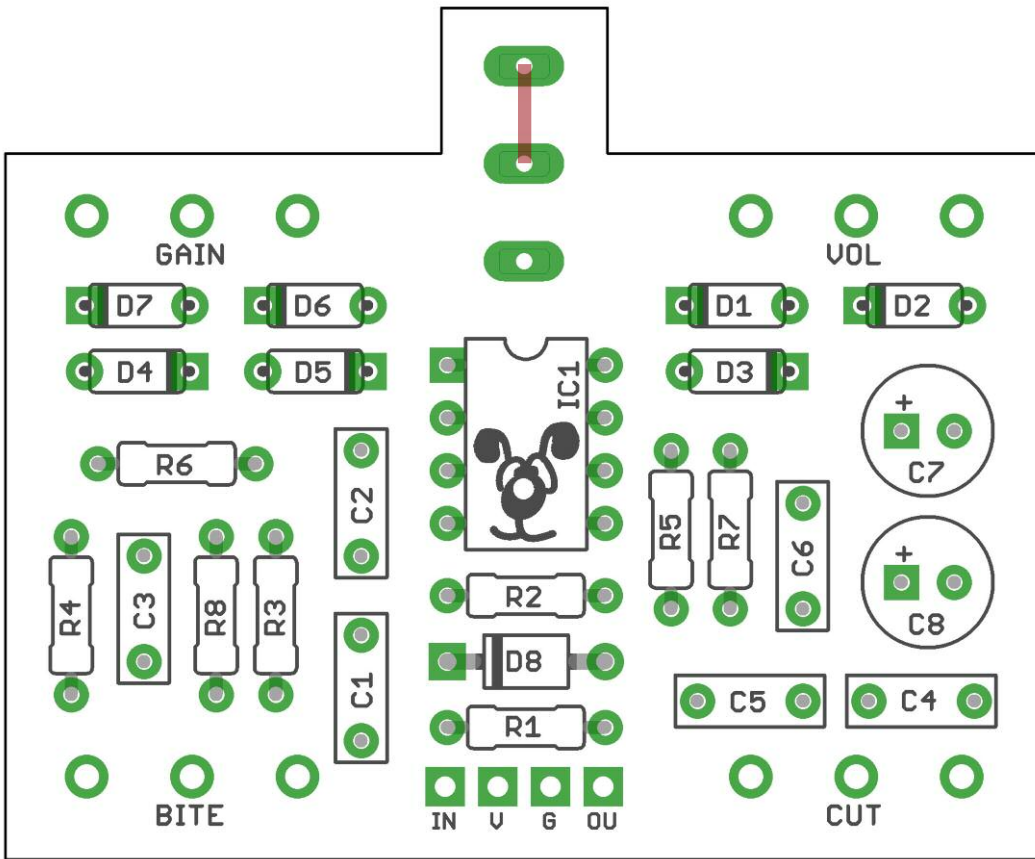

PCB layout ©2019 Pedal Parts Ltd.

The power and signal pads on the PCB conform to the FuzzDog Direct Connection format, so can be paired with the appropriate daughterboard for quick and easy offboard wiring. Check the separate daughterboard document for details.

Be very careful when soldering the diodes. They're very sensitive to heat. You should use some kind of heat sink (crocodile clip or reverse action tweezers) on each leg as you solder them. Keep exposure to heat to a minimum (under 2 seconds). Same goes for the IC if you aren't using a socket.

Snap the small metal tag off the pots so they can be mounted flush in the box.

You should solder all other board-mounted components before you solder the pots. Once they're in place you'll have no access to much of the board. Make sure your pots all line up nicely.

The best way to do that is to solder a single pin of each pot in place then melt and adjust if necessary before soldering in the other two pins. If your pots don't have protective plastic jackets ensure you leave a decent gap between the pot body and the PCB otherwise you risk shorting out the circuit.

CLIPPING

If you're going for the stock clipping only, using D1-3, you need to add a jumper on the switch pads as shown above in red.

Use a SPDT ON-ON if you want to utilise D4-D7 for an alternative. We can't advise on what works well in here - sorry. Play around.

Other options are to leave the extra diode pads empty and add an ON-ON switch to take out the clipping altogether, giving more of a boost than a drive. This will be considerably louder than the clipped option, so take care when switching.

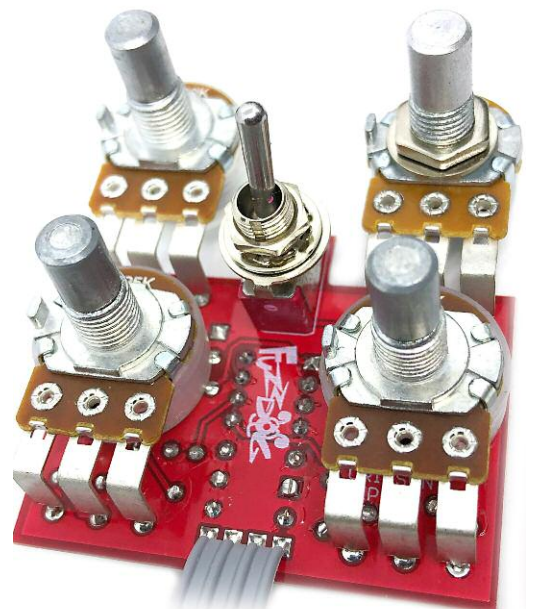

Test the board!

Check the relevant daughterboard document for more info before you undertake this stage.

UNDER NO CIRCUMSTANCES will troubleshooting help be offered if you have skipped this stage. No exceptions.

Once you've finished the circuit it makes sense to test it before starting on the switch and LED wiring. It'll cut down troubleshooting time in the long run. If the circuit works at this stage, but it doesn't once you wire up the switch - guess what? You've probably made a mistake with the switch.

Solder some nice, long lengths of wire to the board connections for 9V, GND, IN and OUT. Connect IN and OUT to the jacks as shown. Connect all the GNDs together (twist them up and add a small amount of solder to tack it). Connect the battery + lead to the 9V wire, same method. Plug in. Go!

If you're using a ribbon cable you can tack the wires to the ends of that. It's a lot easier to take them off there than it is to desolder wires from the PCB pads.

If it works, carry on and do your switch wiring. If not... aw man. At least you know the problem is with the circuit. Find out why, get it working, THEN worry about the switch etc.

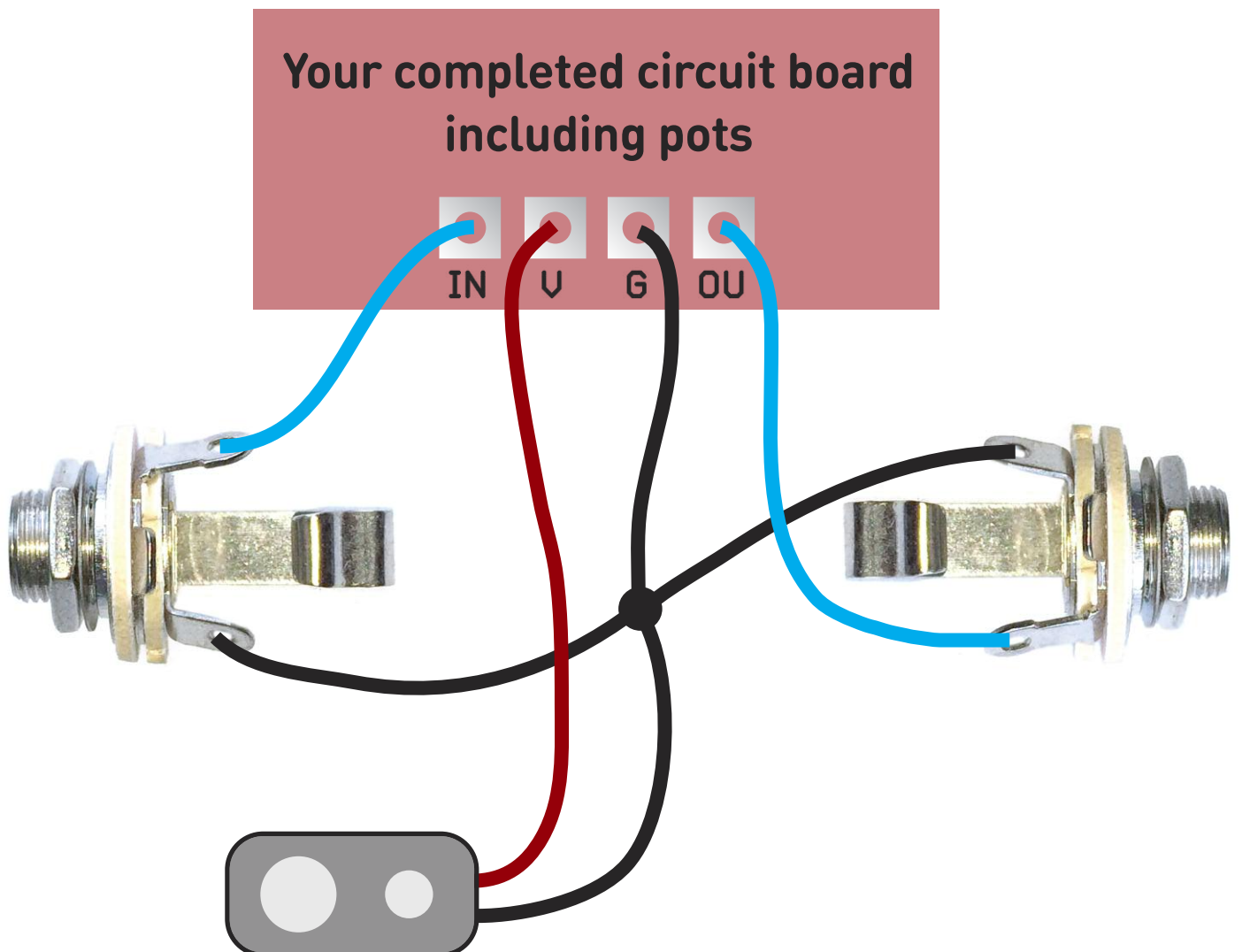

Wire it up (if using a daughterboard please refer to the relevant document)

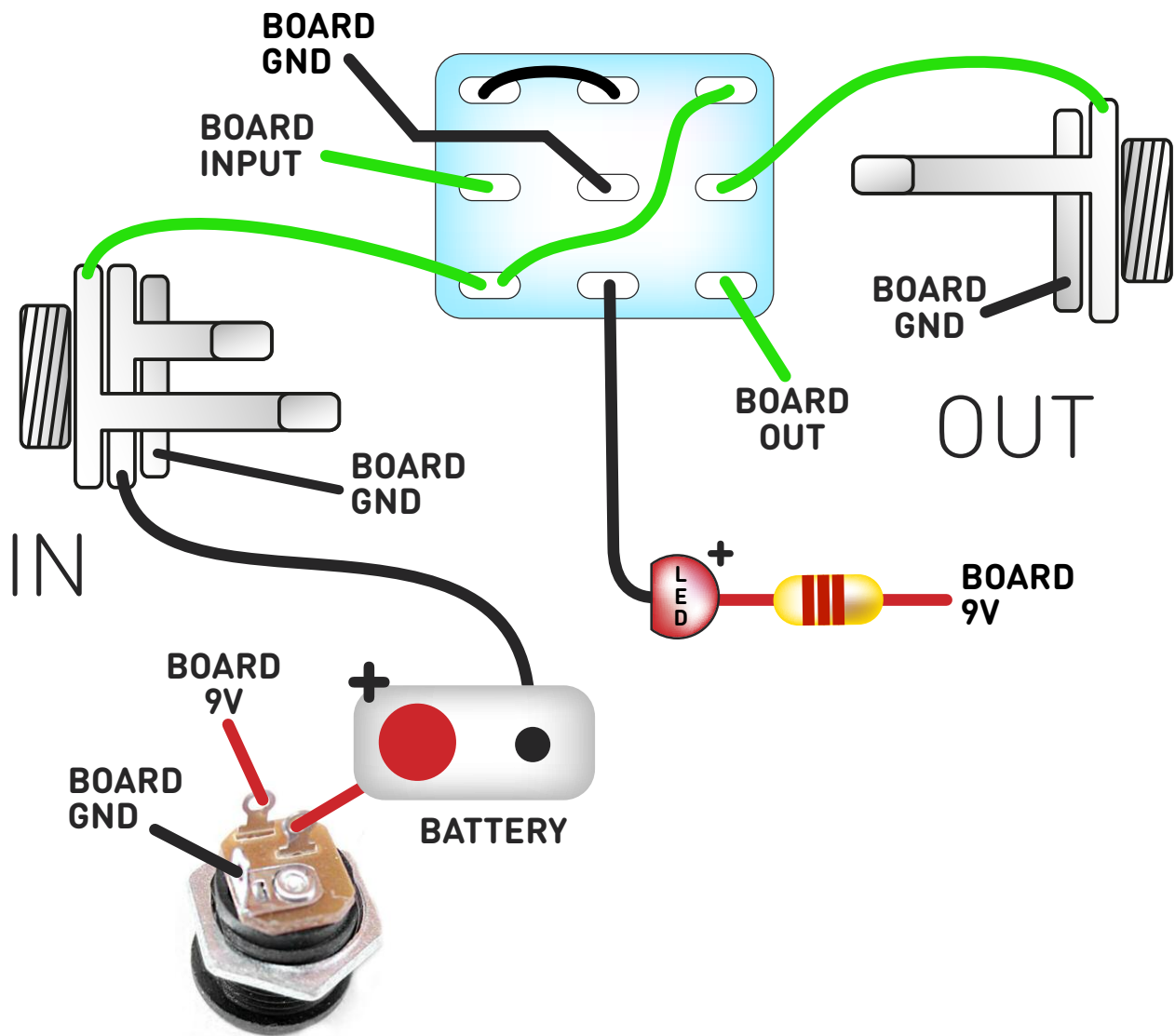

Wiring shown above will disconnect the battery when you remove the jack plug from the input, and also when a DC plug is inserted.

The Board GND connections don't all have to directly attach to the board. You can run a couple of wires from the DC connector, one to the board, another to the IN jack, then daisy chain that over to the OUT jack.

It doesn't matter how they all connect, as long as they do.

This circuit is standard, Negative GND. Your power supply should be Tip Negative / Sleeve Positive. That's the same as your standard pedals (Boss etc), and you can safely daisy-chain your supply to this pedal.

Drilling template

Hammond 1590B
60 x 111 x 31mm

Recommended drill sizes:

Pots	7mm
Jacks	10mm
Footswitch	12mm
DC Socket	12mm
Toggle switches	6mm

It's a good idea to drill the pot and toggle switch holes 1mm bigger if you're board-mounting them.
Wiggle room = good!

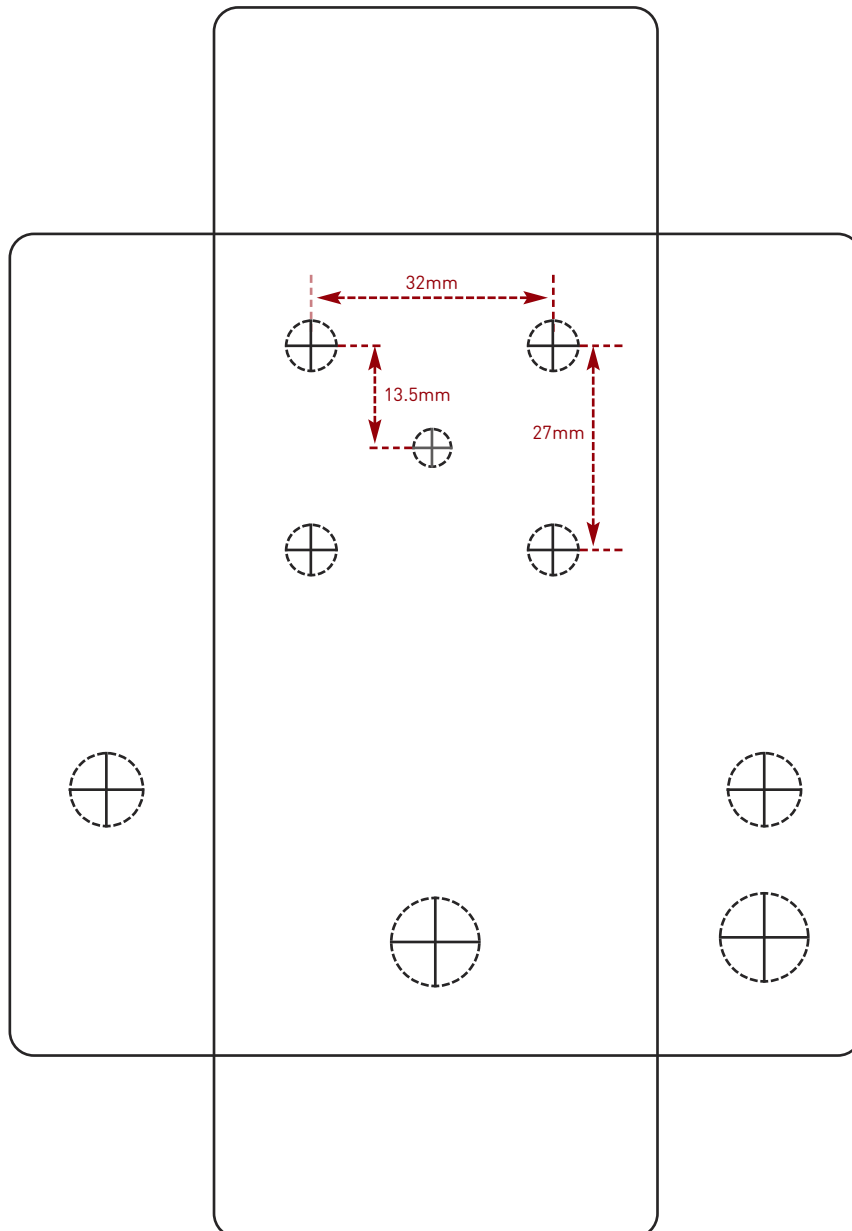

This template is a rough guide only. You should ensure correct marking of your enclosure before drilling. You use this template at your own risk. Pedal Parts Ltd can accept no responsibility for incorrect drilling of enclosures.

FuzzDog.co.uk