

# Chunky Rotter

MiniBoost-based gritbox



Before you dig in, ensure you download and read the **General Build Guide**.

It contains all the information you need for a successful outcome.

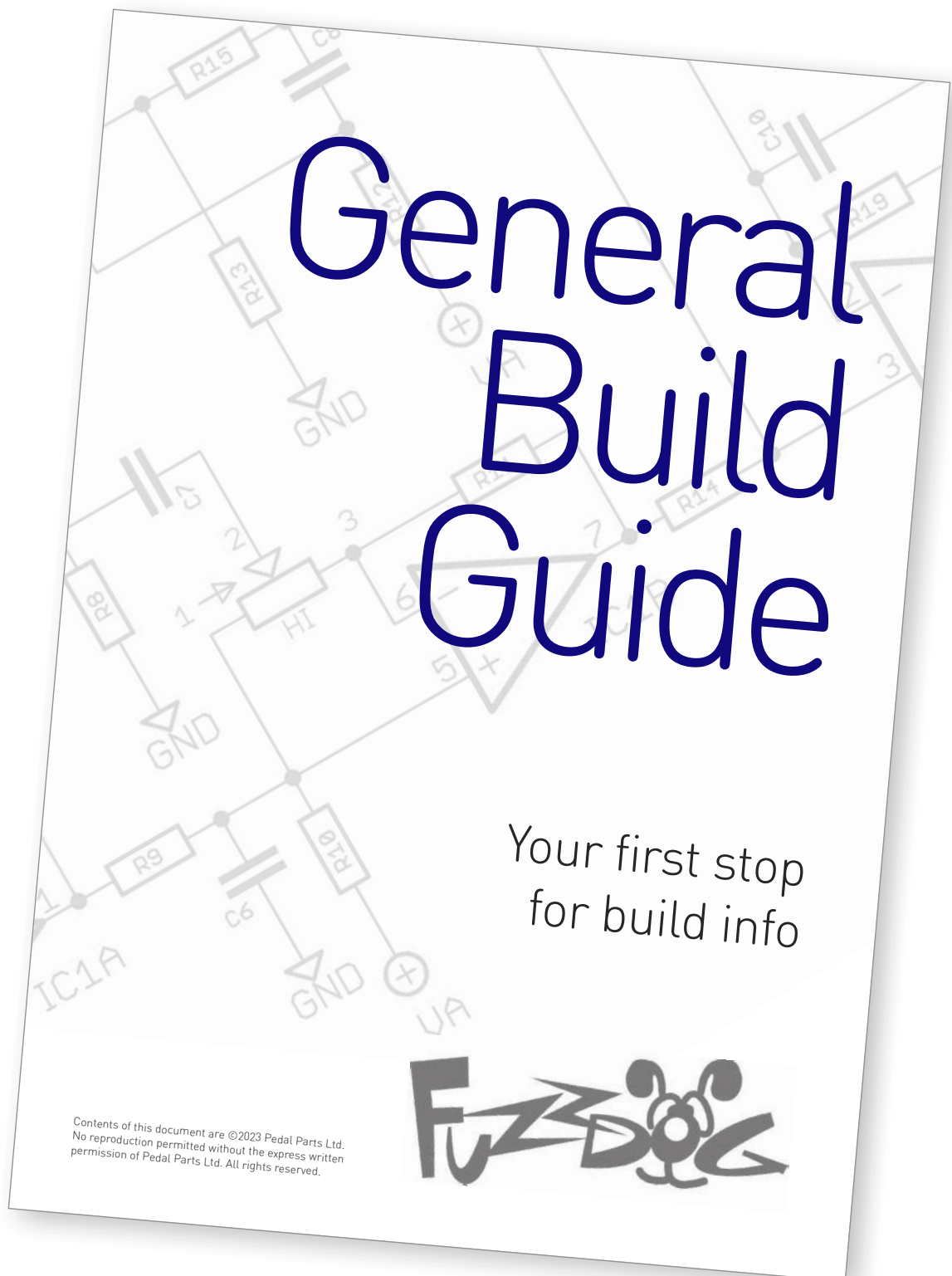





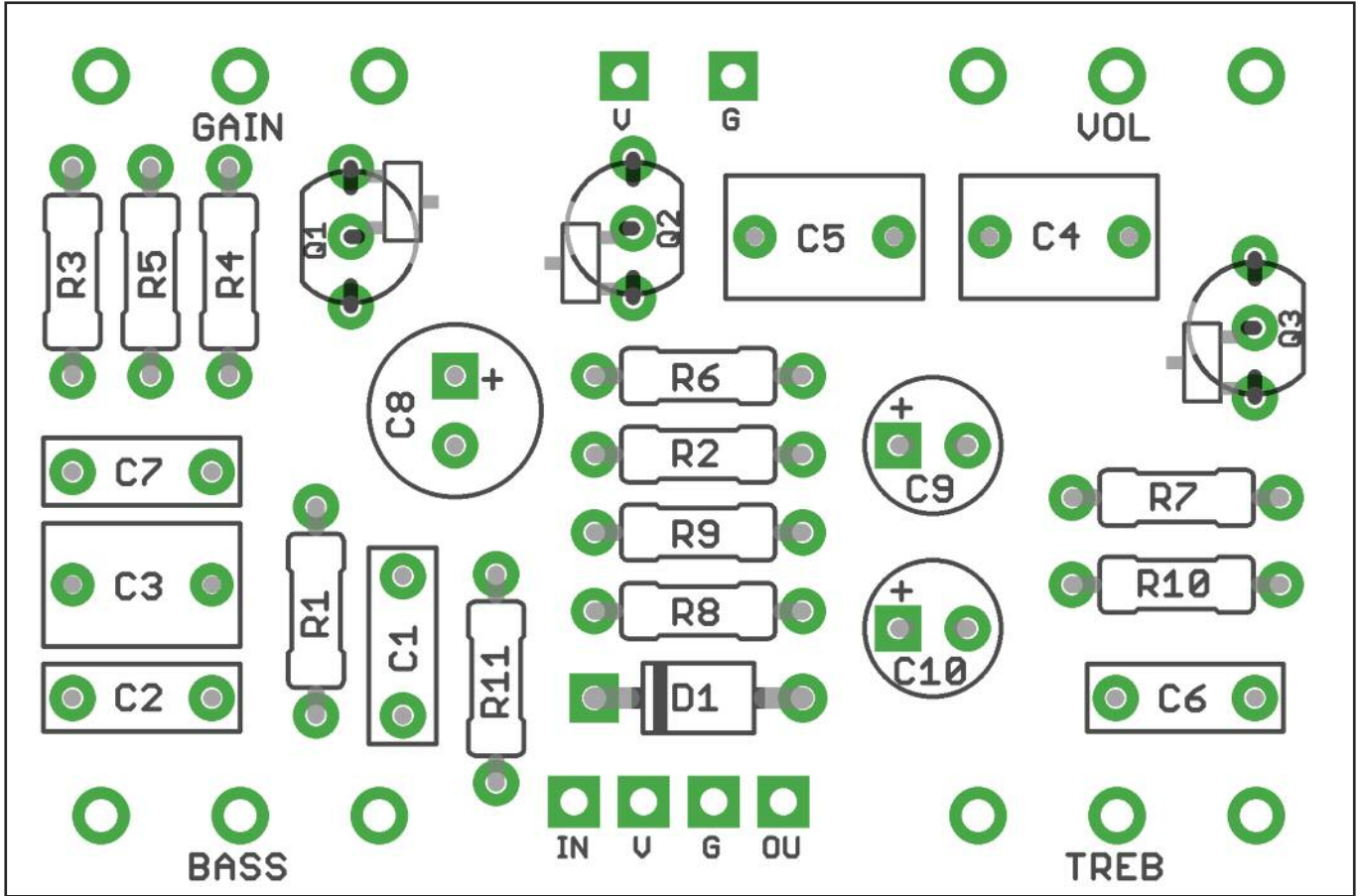

Snap the small metal tag off the pots so they can be mounted flush in the box.

You should solder all other board-mounted components before you solder the pots.

Once they're in place you'll have no access to much of the board.

# Drilling template

**Hammond 1590B - 60 x 111 x 31mm**

Drill sizes listed are minimum.

It's a good idea to add 1mm to anything mounted on the PCB that'll poke through the front of the enclosure.

Drill sizes:

Pots	7mm
Jacks	10mm
Footswitch	12mm
DC Socket	12mm
Toggle switches	6mm
Rotary switches	10mm

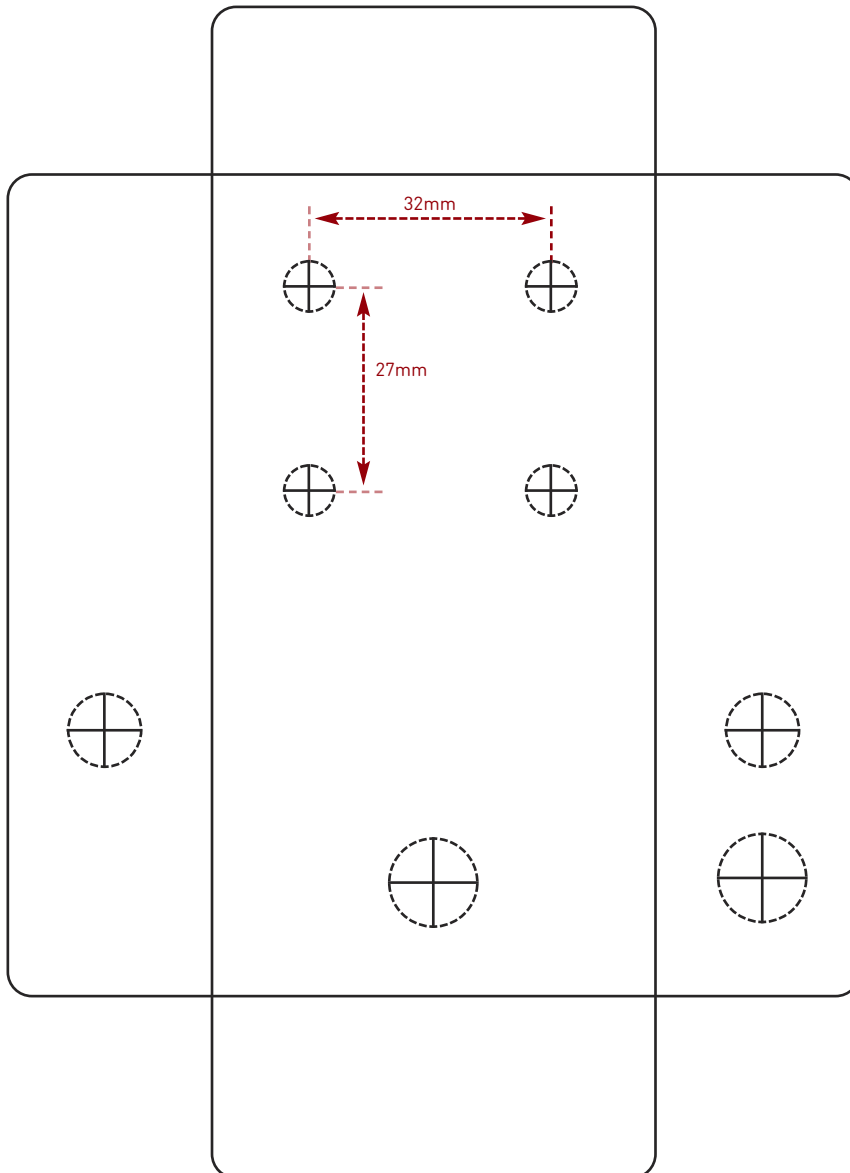

This template is a rough guide only. You should ensure correct marking of your enclosure before drilling. You use this template at your own risk.

Pedal Parts Ltd can accept no responsibility for incorrect drilling of enclosures.

[FuzzDog.co.uk](http://FuzzDog.co.uk)