

# Csound Tremolo V2

Vintage-style wobbling



Before you dig in, ensure you download and read the **General Build Guide**.

It contains all the information you need for a successful outcome.

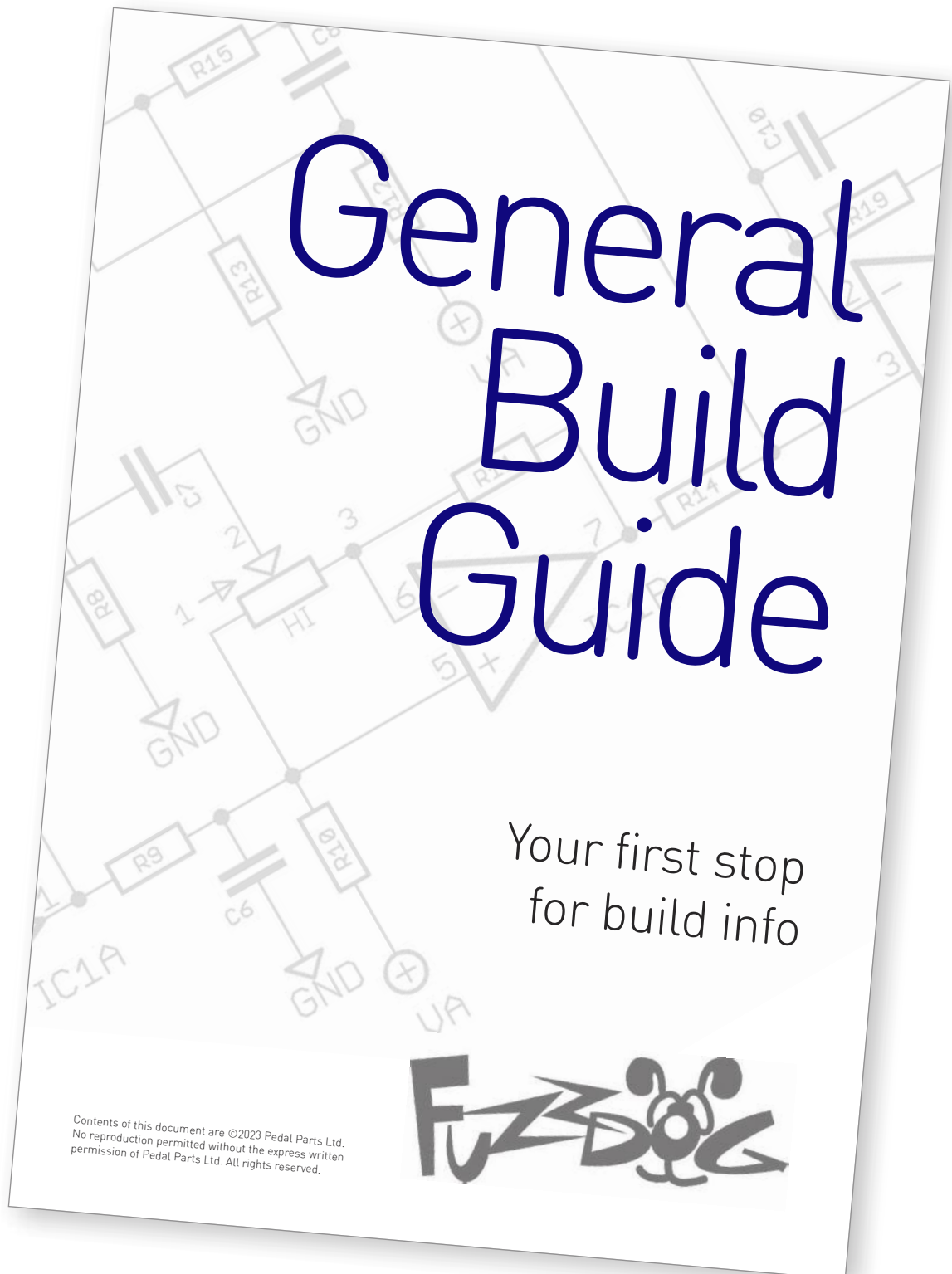

# Schematic + BOM

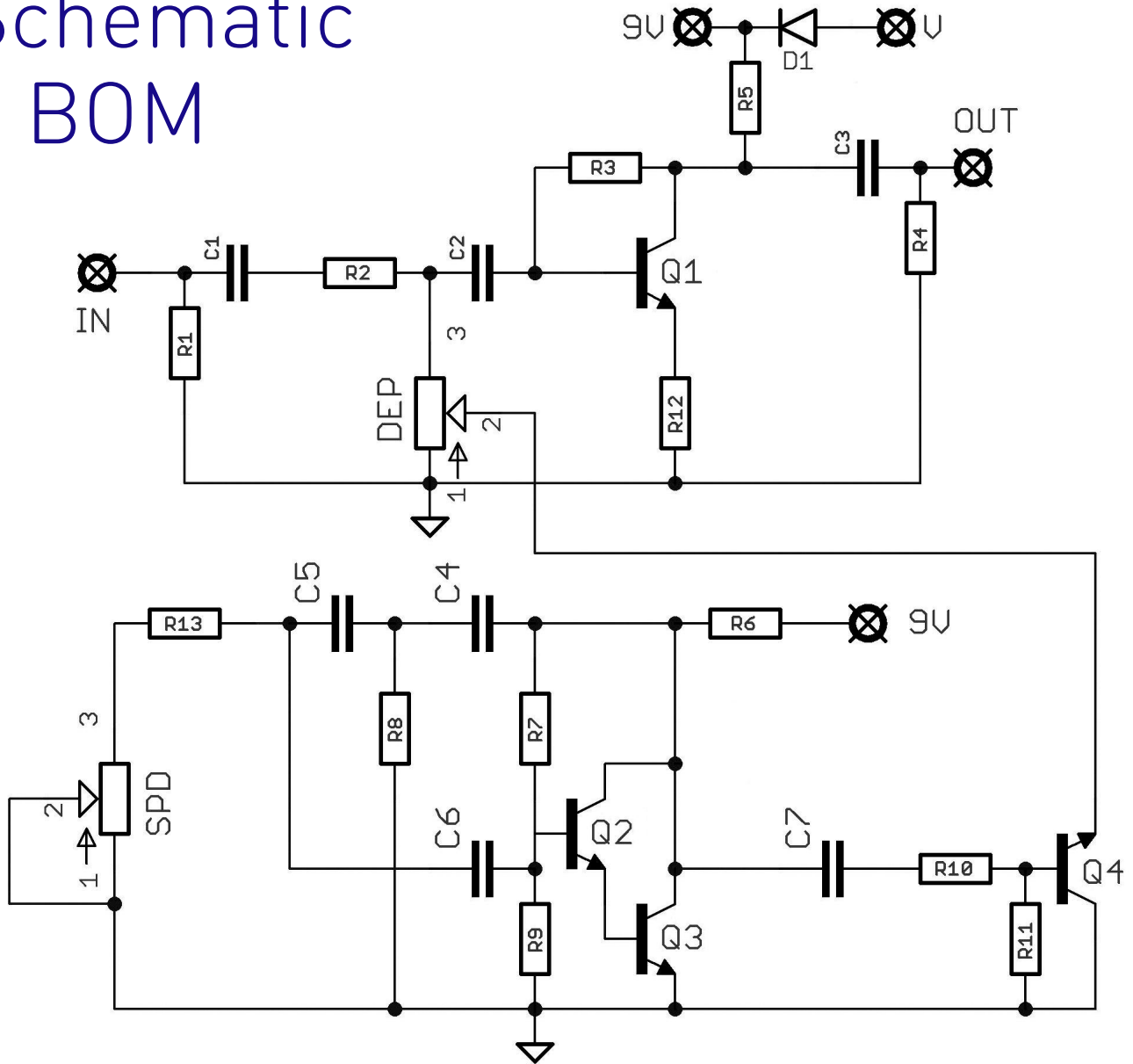

R1	1M	C1	100n	D1	1N5817
R2	100K	C2	100n	Q1-4	2N5088
R3	330K	C3	100n	SPD	100KC
R4	100K	C4	470n	DEP	100KB
R5	18K	C5	470n		
R6	4K7	C6	470n		
R7	3M3	C7	220n		
R8	22K				
R9	3M3				
R10	220K				
R11	1M				
R12	4K7				
R13	3K3				

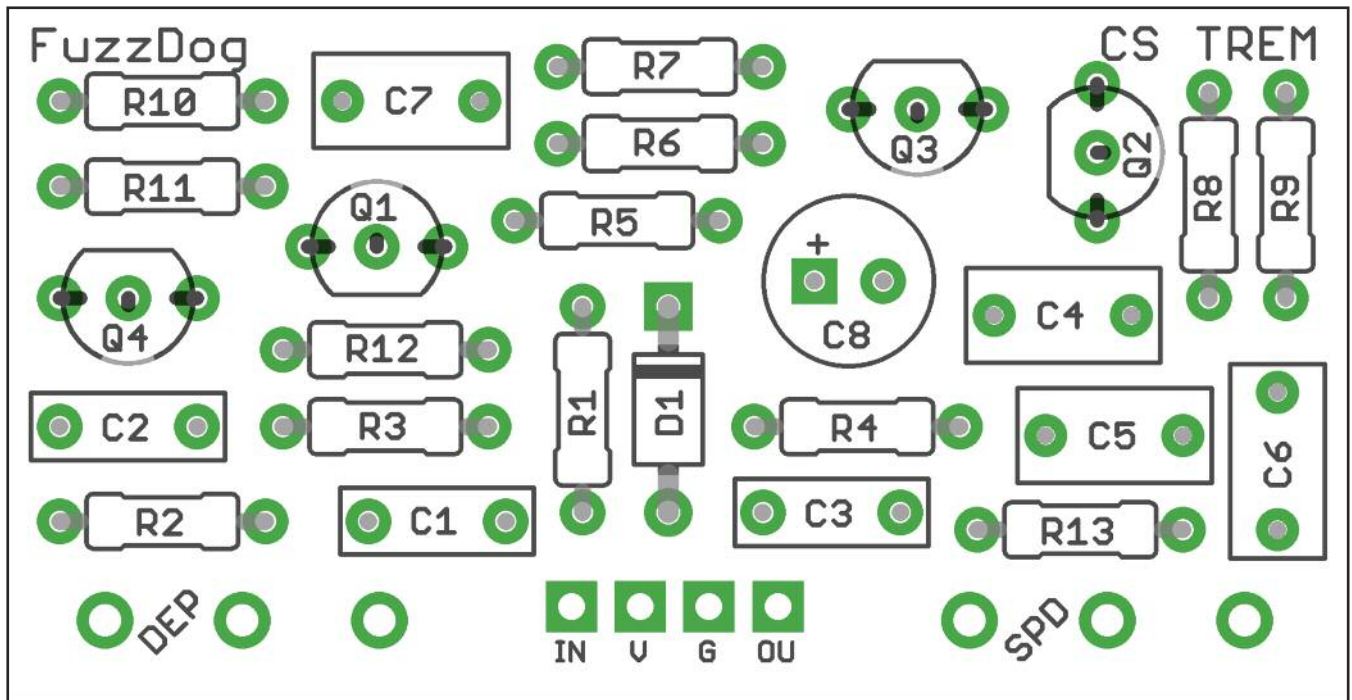

Snap the small metal tag off the pots so they can be mounted flush in the box.

You should solder all other board-mounted components before you solder the pots.

Once they're in place you'll have no access to much of the board.

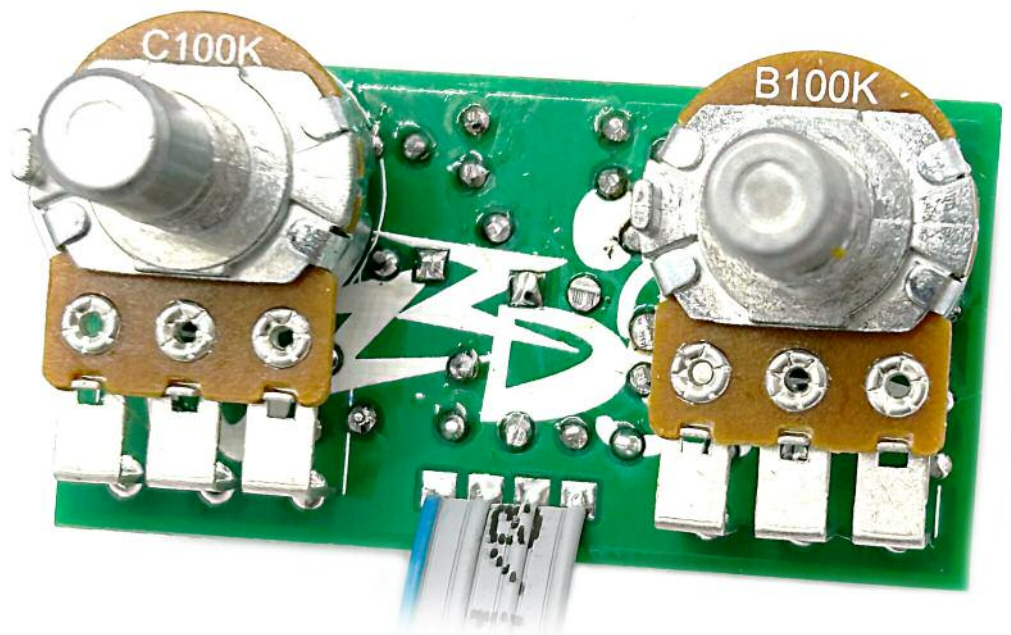

# Drilling template

**Hammond 1590B - 60 x 111 x 31mm**

Drill sizes listed are minimum.

It's a good idea to add 1mm to anything mounted on the PCB that'll poke through the front of the enclosure.

Drill sizes:

Pots	7mm
Jacks	10mm
Footswitch	12mm
DC Socket	12mm
Toggle switches	6mm
Rotary switches	10mm

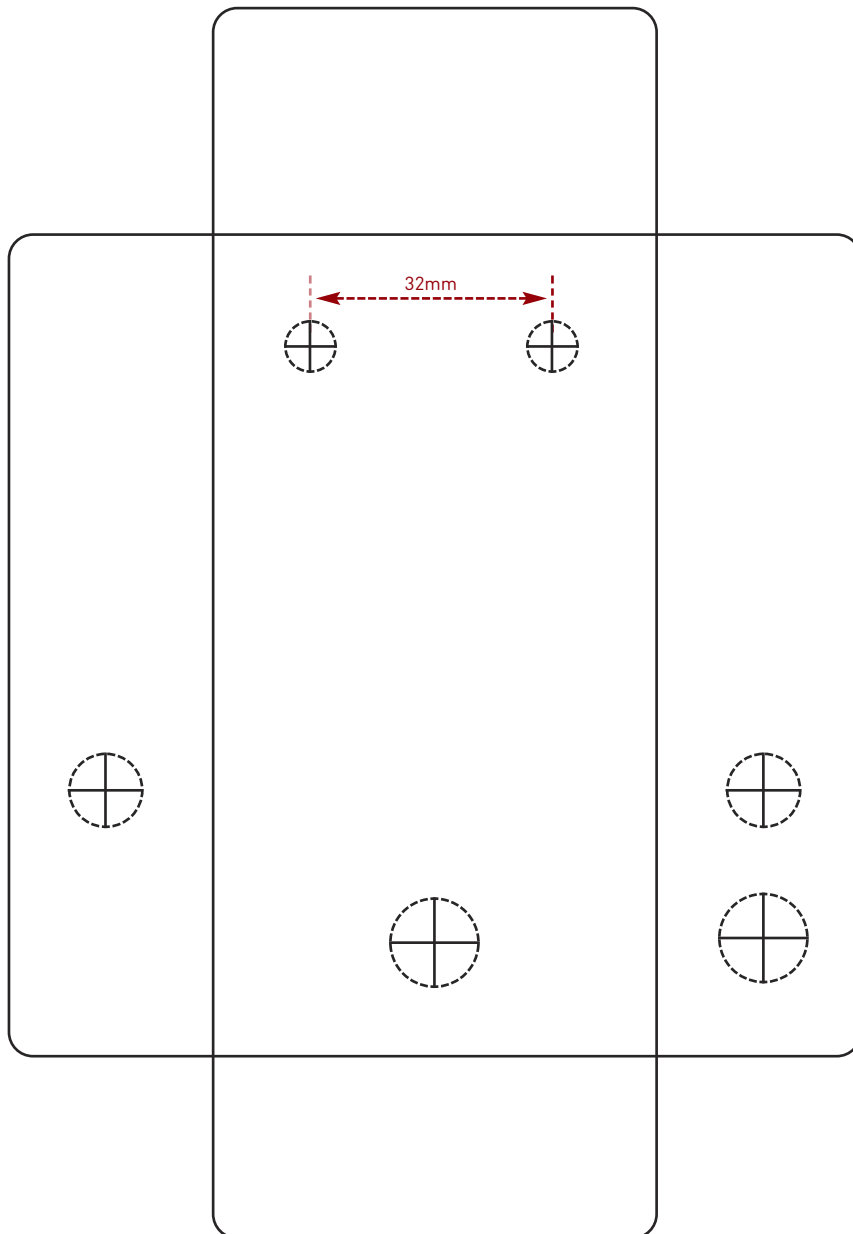

This template is a rough guide only. You should ensure correct marking of your enclosure before drilling. You use this template at your own risk.

Pedal Parts Ltd can accept no responsibility for incorrect drilling of enclosures.

[FuzzDog.co.uk](http://FuzzDog.co.uk)