

Amber Chuck V4

JTM45 in-a-box

Contents of this document are ©2018 Pedal Parts Ltd.
No reproduction permitted without the express written
permission of Pedal Parts Ltd. All rights reserved.

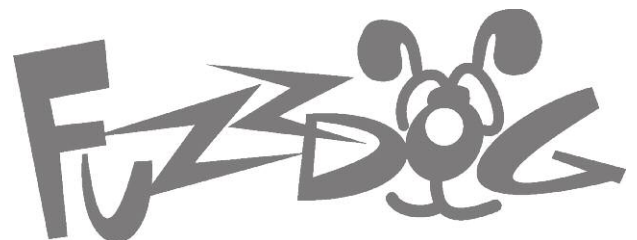

Important notes

If you're using any of our footswitch daughterboards, DOWNLOAD THE DAUGHTERBOARD DOCUMENT

- Download and read the appropriate build document for the daughterboard as well as this one BEFORE you start.
- DO NOT solder the supplied Current Limiting Resistor (CLR) to the main circuit board even if there is a place for it. This should be soldered to the footswitch daughterboard.

COMPONENT SPECS

Unless otherwise stated in this document:

- Resistors should be 0.25W. You can use those with higher ratings but check the physical size of them.
- Electrolytics caps should be at least 25V for 9V circuits, 35V for 18V circuits. Again, check physical size if using higher ratings.

LAYOUT CONVENTIONS

Unless otherwise stated in this document, the following are used:

- **Electrolytic capacitors:**
Long leg (anode) to square pad.
- **Diodes:**
Striped leg (cathode) to square pad.
- **ICs:**
Square pad indicates pin 1.

Schematic + BOM

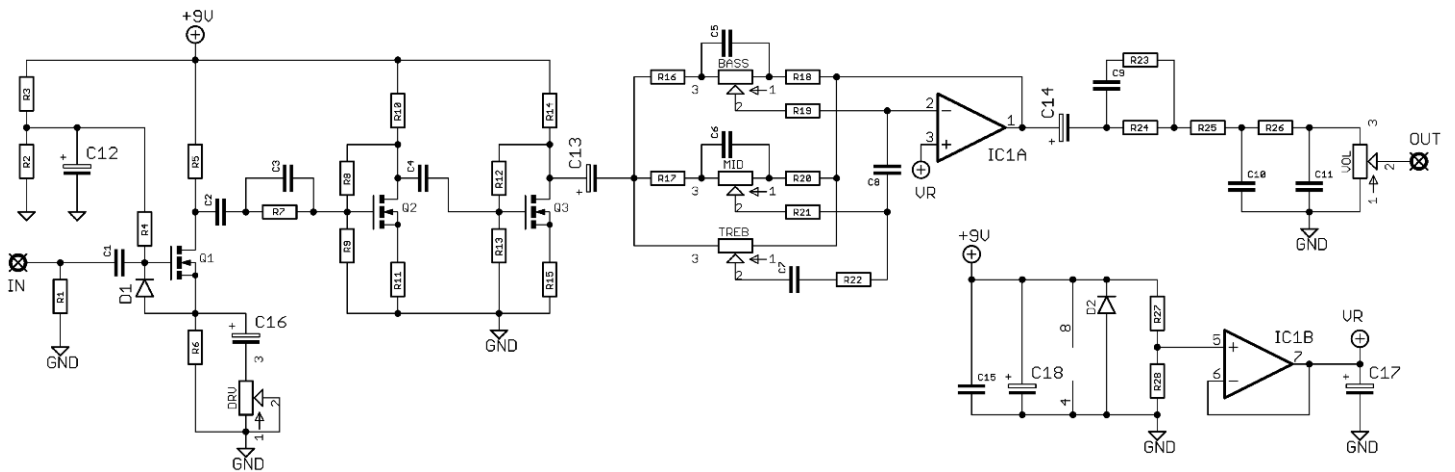

R1	1M
R2	100K
R3	62K
R4	10M
R5	2K7
R6	2K7
R7	470K
R8	1M
R9	1M
R10	5K1
R11	180R
R12	1M
R13	1M
R14	5K1
R15	330R
R16	6K8
R17	2K2
R18	6K8
R19	68K
R20	2K2
R21	15K
R22	10K
R23	47K
R24	91K
R25	100K
R26	10K
R27	22K
R28	22K

C1	22n
C2	100n
C3	470p
C4	22n
C5	47n
C6	10n
C7	2n2
C8	10n
C9	10n
C10	1n
C11	1n
C12	10u elec
C13	10u elec
C14	10u elec
C15	100n
C16	100u elec
C17	100u elec
C18	100u elec

IC1	TL072
Q1-3	BS170
D1	9.1V zener
D2	1N4001
DRV	10KC
VOL	100KA
BASS	25KB
MID	25KB
TREB	25KB

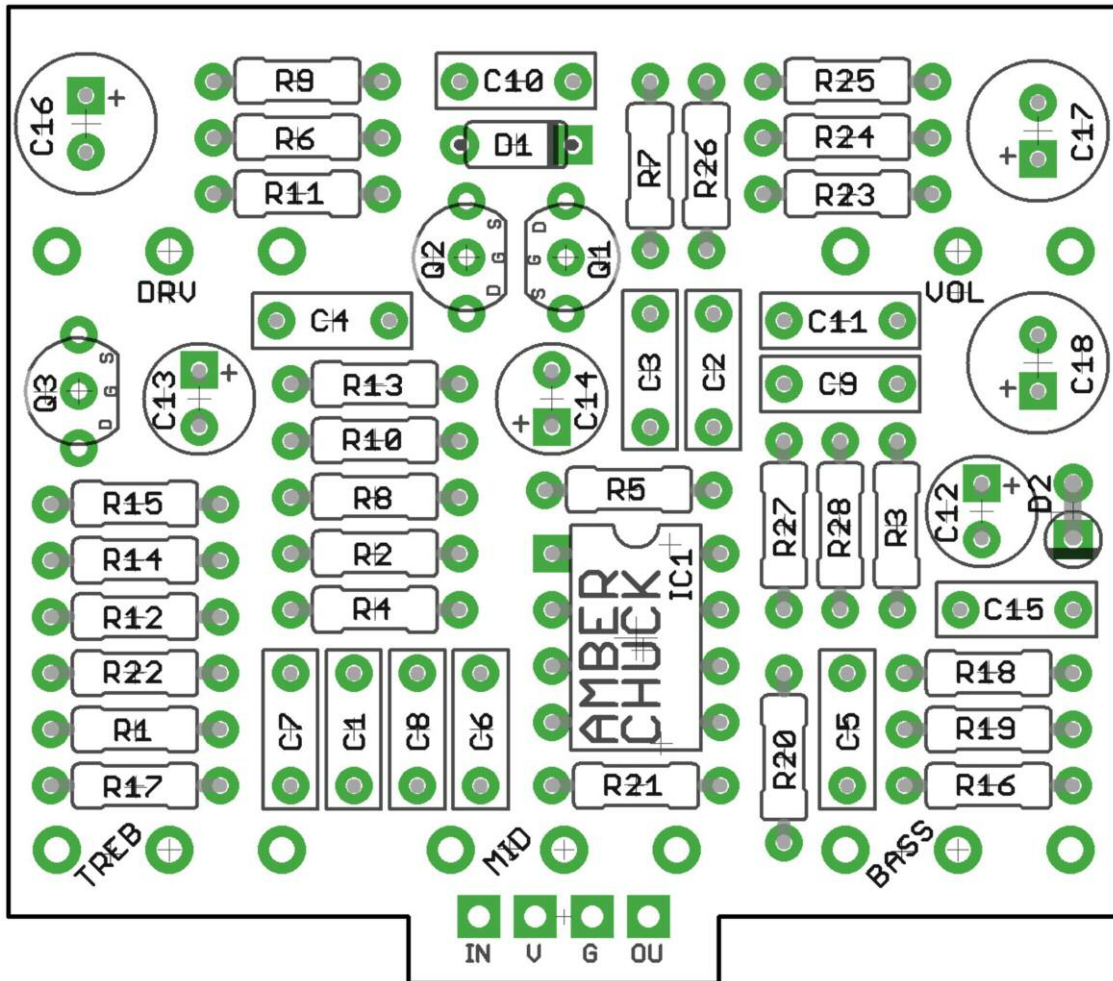

The power and signal pads on the PCB conform to the FuzzDog Direct Connection format, so can be paired with the appropriate daughterboard for quick and easy offboard wiring. Check the separate daughterboard document for details.

Be very careful when soldering the diodes and transistors. They're very sensitive to heat. You should use some kind of heat sink (crocodile clip or reverse action tweezers) on each leg as you solder them. Keep exposure to heat to a minimum (under 2 seconds). Same goes for the IC if you aren't using a socket.

Snap the small metal tag off the pots so they can be mounted flush in the box.

Positive (anode) legs of the electrolytic caps go to the square pads.

Negative (cathode) legs of the diode goes to the square pad.

You should solder all other board-mounted components before you solder the pots. Once they're in place you'll have no access to much of the board. Make sure your pots all line up nicely. The best way to do that is to solder a single pin of each pot in place then melt and adjust if necessary before soldering in the other two pins. If your pots don't have protective plastic jackets ensure you leave a decent gap between the pot body and the PCB otherwise you risk shorting out the circuit.



Test the board!

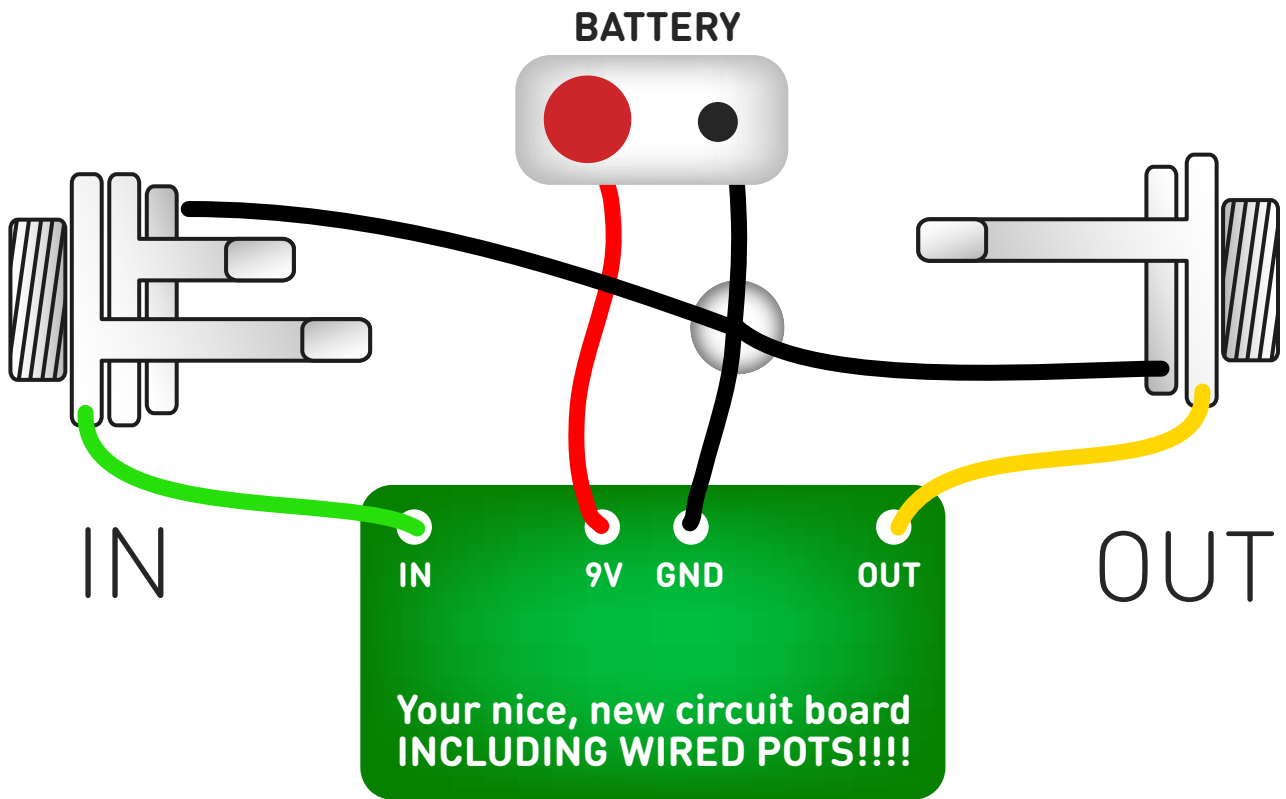

UNDER NO CIRCUMSTANCES will troubleshooting help be offered if you have skipped this stage. No exceptions.

Once you've finished the circuit it makes sense to test it before starting on the switch and LED wiring. It'll cut down troubleshooting time in the long run. If the circuit works at this stage, but it doesn't once you wire up the switch - guess what? You've probably made a mistake with the switch.

Solder some nice, long lengths of wire to the board connections for 9V, GND, IN and OUT. Connect IN and OUT to the jacks as shown. Connect all the GNDs together (twist them up and add a small amount of solder to tack it). Connect the battery + lead to the 9V wire, same method. Plug in. Go!

If it works, carry on and do your switch wiring. If not... aw man. At least you know the problem is with the circuit. Find out why, get it working, THEN worry about the switch etc.

Wire it up (if using a daughterboard please refer to the relevant document)

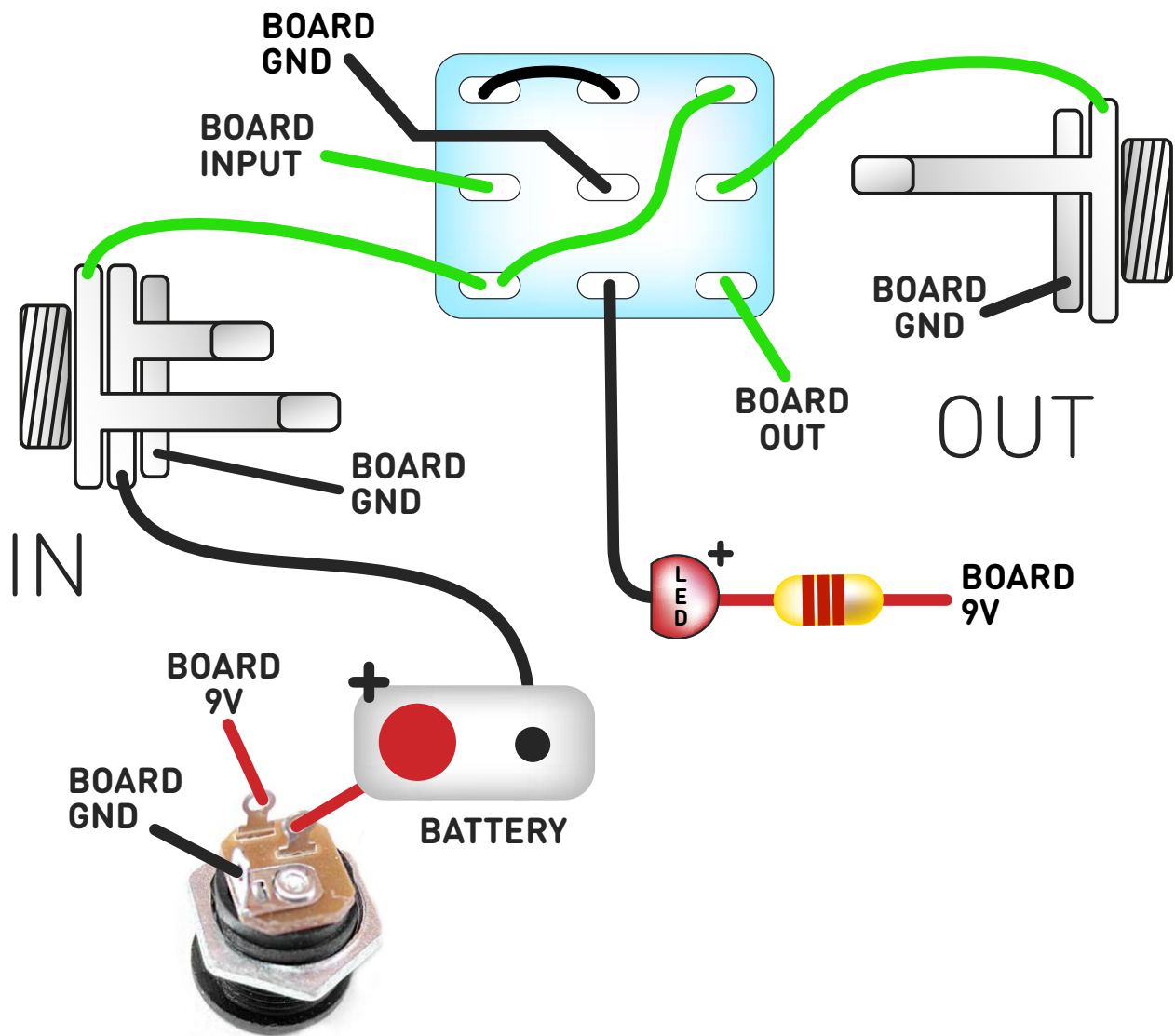

Wiring shown above will disconnect the battery when you remove the jack plug from the input, and also when a DC plug is inserted.

The Board GND connections don't all have to directly attach to the board. You can run a couple of wires from the DC connector, one to the board, another to the IN jack, then daisy chain that over to the OUT jack.

It doesn't matter how they all connect, as long as they do.

This circuit is standard, Negative GND. Your power supply should be Tip Negative / Sleeve Positive. That's the same as your standard pedals (Boss etc), and you can safely daisy-chain your supply to this pedal.

Drilling template

Hammond 1590B
60 x 111 x 31mm

Recommended drill sizes:

Pots	7mm
Jacks	10mm
Footswitch	12mm
DC Socket	12mm

It's a good idea to drill the pot and toggle switch holes 1mm bigger if you're board-mounting them.
Wiggle room = good!

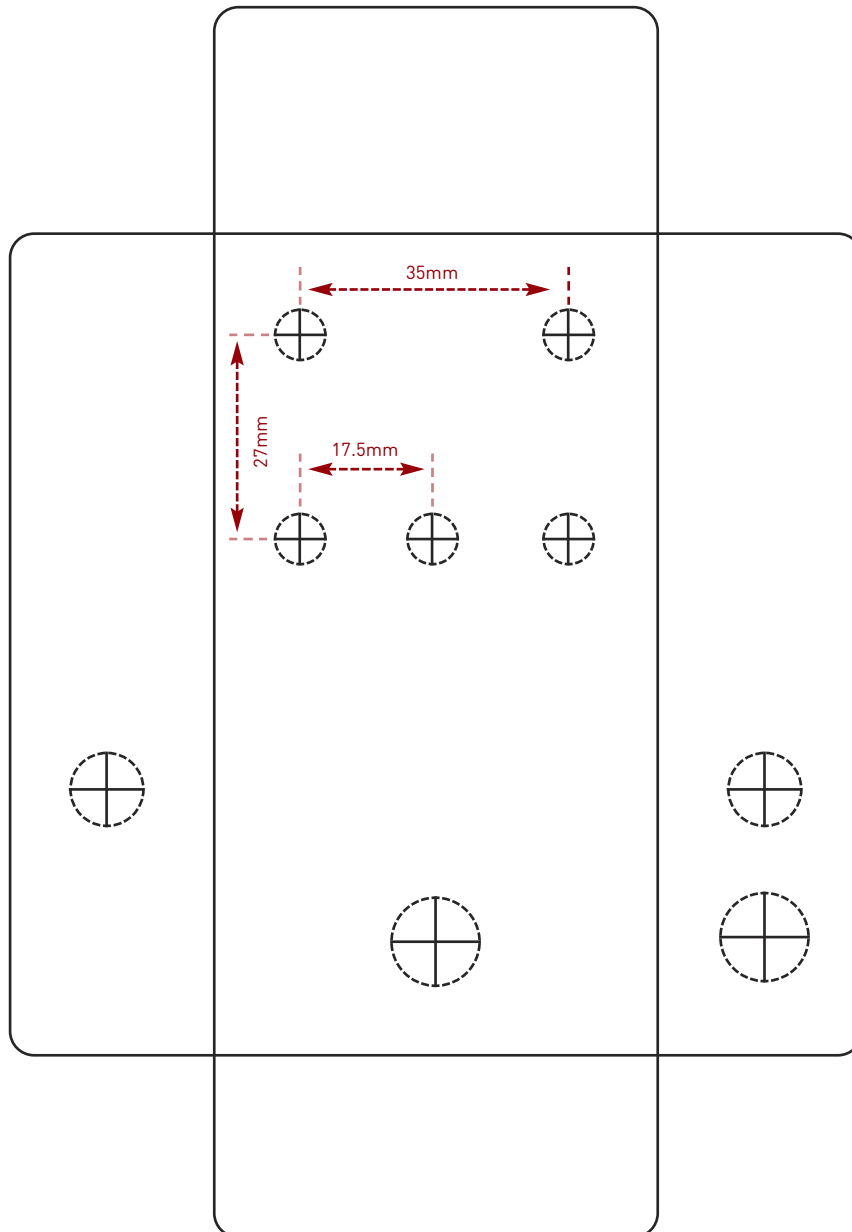

This template is a rough guide only. You should ensure correct marking of your enclosure before drilling. You use this template at your own risk.
Pedal Parts Ltd can accept no responsibility for incorrect drilling of enclosures.

FuzzDog.co.uk